

Operation Manual of Solar Controller

SR223 for Split Solar System



 Read the instruction carefully please before operation!

Content

1. Safety Information	5
1.1. Installation and commissioning	5
1.2. About this manual.....	5
1.3. Liability waiver	5
1.4. Important messages.....	6
1.5. Signal description	6
1.6. HMI key explanation.....	6
1.7. Meaning of icons appeared on the screen	7
2. Overview	8
2.1. Controller introduction	8
2.2. Delivery list.....	8
2.3. Technical data	8
3. Installation	9
3.1. Mounting controller.....	9
3.2. Wiring connection.....	10
3.3. Terminal connection	10
4. System introduction.....	13
4.1. Overview of the available systems	13
4.2. Description of 7 systems	14
4.2.1. System 1: Standard solar system with 1 tank, 1 collector field	14
4.2.2. System 2: Solar system with 1 collector field, 2 tanks and thermal energy transferring between 2 tanks.....	16
4.2.3. System 3: Solar system with 1 collector field, 1 tank, 3-ways valve for tank loading in layers	18
4.2.4. System 4: Solar system with 1 collector field, 2 tanks, valve logic control.....	19
4.2.5. System 5: Solar system with 1 collector field, 2 tanks, pump - logic control.....	21
4.2.6. System 6: Solar system with east/west collector fields, 1 tank	22
4.2.7. System 7: Solar system with 1 collector field, 1 tank, loading the heating return	24
4.3. Commissioning.....	25
5. Functions and options	26
5.1. Overview of menu structure	26
5.2. Menu operation description	26

5.3.Check value	27
5.4.Shortcut trigger function of back-up heating, circuit pump and WiFi reset information	27
6.Menu function and parameter set (for user)	28
6.1.Date(Time/ Date set)	28
6.2.THET Timed back-up heating.....	29
6.3.CIRC DHW circuit pump controlled by temperature in three time - sections / flow switcher and by three time sections	35
Function operation and parameter setting (expertise).....	42
6.4.PRSWD Password	42
6.5.SYS system selection.....	43
6.6 ./ 6.7. LOAD/LOAD2 Tank heating set	44
6.8./6.9. COL/COL2 Collector function	47
6.10.PUMP Pump control mode	55
6.11.LLOGITank priority logic.....	58
6.12.COOLCooling function	62
6.13.HEATX Energy exchange between tanks	67
6.14.RPH Heating return pipe preheat	70
6.15.SFB Solid fuel boiler function	71
6.16.AH Thermostat function.....	74
6.17.BEEP Beeper fault warning.....	77
6.18.MAN Manual mode.....	78
6.19.BLPR Block protection function.....	79
6.20.OTDI Thermal disinfection function	80
6.21.OPARR Parallel relay.....	82
6.22.OHQM Heat quantity measurement	83
6.23.FS Flow meter selection and flow rate monitor.....	86
6.24.UNIT Unit switch.....	89
6.25.WLAN WiFi module configuration.....	90
6.26.RST Reset.....	91
6.27.PASS Password set.....	93
7.Holiday function.....	93
8.Protection function.....	94

8.1.Screen protection	94
8.2.Trouble protection	94
8.3.Trouble checking	95
9.Quality Guarantee	98
10.Accessories	99

SR223 WiFi App User Manual (The function need optional configuration)

1. Safety Information

1.1. Installation and commissioning

When laying wires, please ensure that no damage occurs to any of the constructional fire safety measures presented in the building.

The controller should not be installed in rooms where easily inflammable gas mixtures are present or may occur.

The permissible environmental conditions can't be exceeded at the site of installation.

Before connecting the device, please make sure that the power supply matches the specifications that controller requires.

All devices connected to the controller must conform to the technical specifications of the controller.

All operations on an open controller are only conducted cleared from the power supply. All safety regulations for working on the power supply are valid.

Connecting and / or all operation that require opening the controller (e.g. changing the fuse) are only conducted by specialists.

1.2. About this manual

This manual describes the installation, functions and operation of a solar controller. When installing the remaining components e.g. the solar collectors, solar pump station and the tank unit etc, please ensure to observe the appropriate installation instructions provided by each manufacturer. Device's installation, Electrical wire connection, commissioning and maintenance of the device may only be performed by trained professional person. The professional person must be familiar with this manual and follow the instructions contained herein.

1.3. Liability waiver

The manufacturer can't monitor the compliance with these instructions or the circumstances and methods used for installation, operation, utilization and maintenance of this controller. Improper installation can cause damages to material and person. This is the reason why we do not take over responsibility and liability for losses, damages or cost that might arise due to improper installation, operation or wrong utilization and maintenance or that occurs in some connection with the above-mentioned. Moreover, we do not take over liability for patent infringements or infringements –

occurring relating to the use of this controller on the third parties' rights. The manufacturer preserves the right to put changes to product, technical data or installation and operation instructions without prior notice. As soon as it becomes evident that safe operation is no longer possible (e.g. visible damage). Please immediate take the device out of operation. Note, ensure that the device can't be accidentally placed into operation.

1.4.Important messages

We have carefully checked the text and pictures of this manual and provided the best of our knowledge and ideas, however inevitable errors maybe exist. Please note that we cannot guarantee that this manual is given in the integrity of image and text, they are just some examples, and they apply only to our own system. Incorrect, incomplete and erroneous information and the resulting damage we do not take responsibility.

1.5.Signal description



Safety indication: Safety instructions in the text are marked with a warning triangle. They indicate measures which can lead to injury of person or safety risks.

Operation steps: small triangle "►Press" is used to indicate operation step.



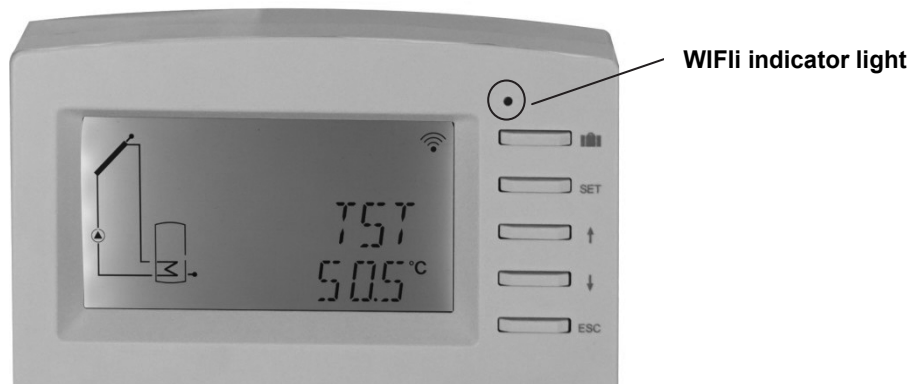

Notes: Icon contains important information about operation or functions.

1.6.HMI key explanation



















Controller is operated with the 5 keys beside the screen

- “  ” holiday key
- “ SET ” key: confirm / selection
- “ ↑ ” upwards key: increase the value
- “ ↓ ” downwards key: reduce the value
- “ESC” return/ exit key: confirm setting and return to the previous menu

 Note: TST showed on the screen is temperature of tank 1

1.7.Meaning of icons appeared on the screen

Icon Meaning	Code	Icon is lighting	Icon is blinking
Exceed the maximum temperature of tank	SMX		
Running of tank emergency shutdown function	LEM		 + 
Running of collector emergency shutdown function	CEM		
Running of collector cooling function	CMAX		
Running of tank cooling function	OSTC		
Running of system cooling function	OSYC		
Enabling the collector anti-freezing function			
Running of collector anti-freezing function	CFRO		 + 
Enabling the collector minimum temperature function	CMIN		
Error of temperature sensor	T ----		
Error of flow sensor	L/M ----		 + 

2.Overview

2.1.Controller introduction

LCD large display screen

5 * relay outputs

1 * low voltage relay output for boiler on/off control

7 * sensor inputs

1 * Input for Grundfos Direct Sensor TM (VFS)

1 * Input for (FRT)rotary blade electronic flow meter

3 * Variable frequency PWM outputs for the speed control of the high efficiency pump

7 systems available for selection



2.2.Delivery list

1 * SR223 controller

1 * user manual

2 * screw and plastic bolt

2 * P1000 temperature sensor ($\phi 6 \times 50$ mm,cable length 1.5meter)

4 *NTC10K temperature sensor ($\phi 6 \times 50$ mm,cable length 3meter)

1 *Accessories bag

2.3.Technical data

● Inputs:

2* PT1000 temperature sensors

5* NTC10K, B=3950 temperature sensors

1* analog input for Grundfos Direct Sensor TM (VFS)

1* input for Rotary blade electronic flow meter(FRT)

● Output:

2* Electromagnetic relay, Max. current 1A

3* Semiconductor relay, Max. current1A

1* low voltage relay (on/off signal) , boiler on/off control

3* PWM variable frequency output (switchable 0-10V)

- Functions: running hour counter, tube collector function, timed thermostat function, pump speed control, heat quantity measurement, external heat exchange, system parameters adjusting, optional functions adjusting (menu-structure), balance and diagnostic etc.
- Power supply: 100...240V ~ (50...60Hz)
- Rated impulse voltage:2.5KV
- Housing: Plastic ABS
- Mounting: Wall mounting
- Indication / Display: System-Monitoring-Display, for visualization of the systems, LCD display, and background illumination
- Operation: 5 push keys at the front cover
- Protection type: IP41
- Protection class: I
- Ambient temperature: 0 ... 40 °C
- Dimensions: 208*158*43mm

3.Installation



Note: The unit should only be installed in the dry interior rooms. Please separate routing of sensor wires and mains wires. Make sure the controller as well as the system are not exposed to the strong electromagnetic fields

3.1.Mounting controller

Follow the below steps to mount the controller on the wall.

- Unscrew the cross - head screw from the cover and remove it along with the cover from the housing.
- Mark the upper fastening point on the wall. Drill on the wall, and fasten the enclosed wall plug and screw
- Hang the housing on the upper fastening point and mark the lower fastening points (centers 180 mm).
- Drill and insert lower wall plugs.
- Fasten the housing on the wall with the lower fastening screw and tighten.
- Connect cables according to the terminal allocation diagram.

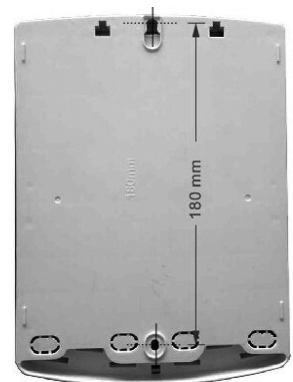

- Put the cover on the housing, fastening screw.

3.2. Wiring connection

Connect cables according to the terminal allocation diagram. According to the way of installation, wire can be connected from hole A on the bottom plate or from hole B, using a suitable tool (like knife) to cut the plastic of A.

Note: wires must be fastened by fixing clamps on position C.

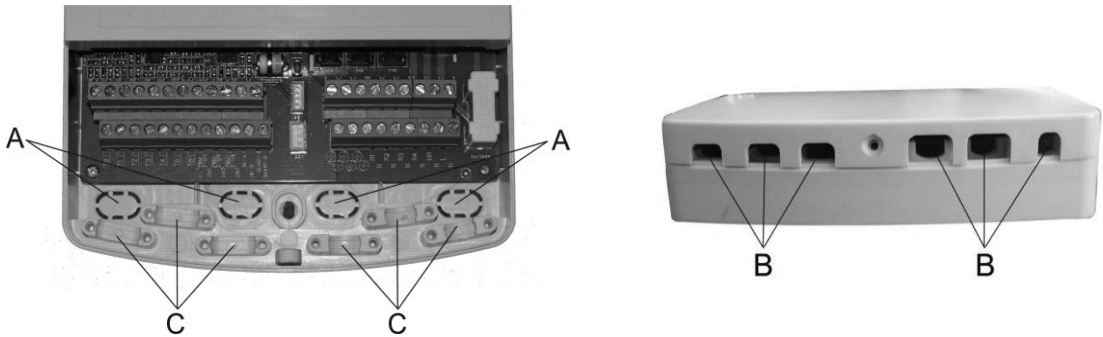

3.3. Terminal connection



before opening the housing! Always disconnect the controller from power supply and obey the local electrical supply regulation.

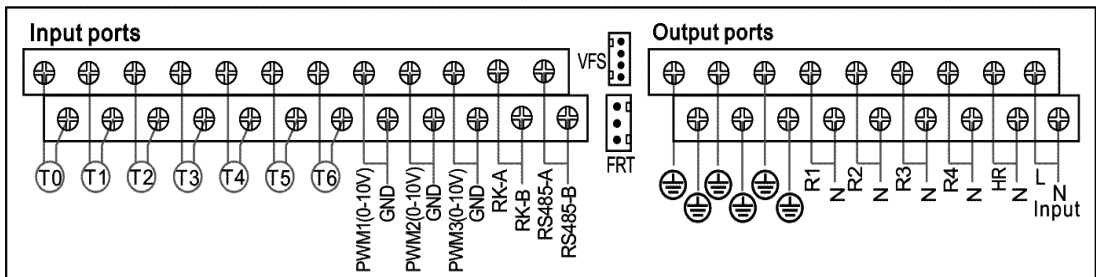

- Input terminals

T0~T1: PT1000 temperature sensor, for measuring the temperature of collector

T2~T6: NTC10K, B=3950 temperature sensor, for measuring temperature of tank and pipe

PWM1,PWM2, PWM3: Signal ports for high efficiency pump, detailed connection see below pump connection

RK-A, RK-B: on/off signal ports, (RK and HR simultaneously open or close, for boiler heating control)

Communication port 485: ELA485, for connecting with communication module.

FRT: For rotary blade electronic flow meter

VFS: For Grundfos flow meter sensor

- Advice regarding the installation of temperature sensors:

1) Only original factory equipped Pt1000 temperature sensors are approved for using on the collector, it is equipped with 1.5m silicon cable and suitable for all weather conditions, the cable is temperature resistant up to 280°C, connect the temperature sensors to the corresponding terminals with either polarity.

2) Only original factory equipped NTC10K,B=3950 temperature sensors are approved for using on tank and pipe, it is equipped with 3m PVC cable, and the cable is temperature resistant up to 105°C, connect the temperature sensors to the corresponding terminals with either polarity.

3) All sensor cables carry low voltage, and to avoid inductive effects, ensure it not be laid close to 230 Volt or 400 Volt cables (minimum separation of 100mm).

4) If external inductive effects are existed, e.g. from heavy current cables, overhead traincables, transformer substations, radio and television devices, radio stations, microwave devices etc., then the cables to the sensors must be adequately shielded.

5) Sensor cables may be extended to a maximum length of ca. 100 meter, when cable's length is up to 50m, and then 0.75mm² cable should be used. When cable's length is up to 100m, and then 1.5mm² cables should be used.

- Output terminal

Input Ports L, N: for power connection, L: live wire, N: zero wire,  protective ground wire

Output R1: Semiconductor relays (SCR), designed for pump speed control, Max. Current: 1A

Output R2: Semiconductor relays (SCR), designed for pump speed control, Max. Current: 1A

Output R3: Semiconductor relays (SCR), designed for pump speed control, Max. Current: 1A

Output R4: Electromagnetic relays, designed for on/off control of pump or 3-ways electromagnetic valve, Max. Current: 1A

Output HR: Electromagnetic relays, designed for on/off control of back-up heating device, Max. current: 1A

- Wiring high efficiency pump

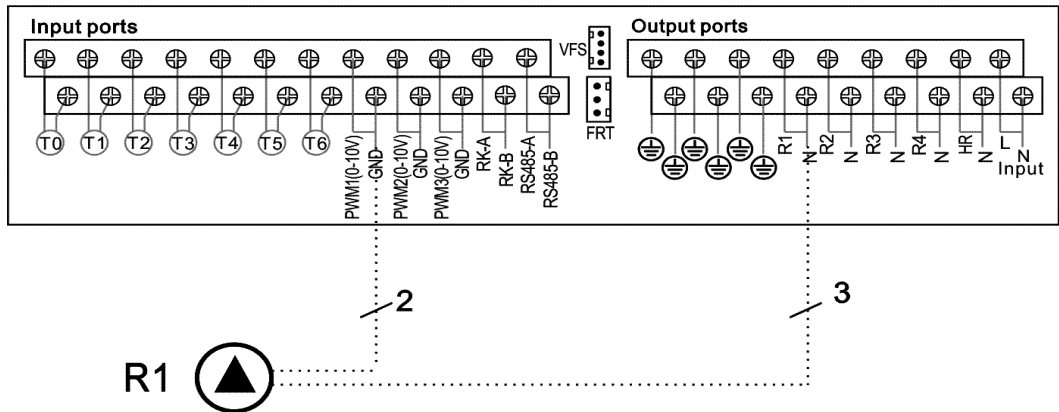

- Wiring the signal cable from the high-efficiency pump

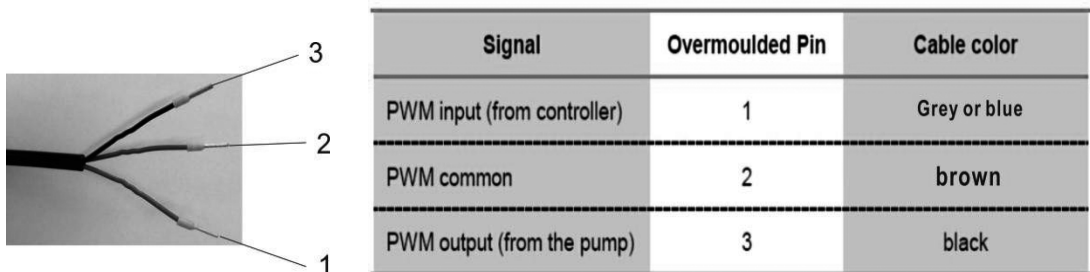

Signal cable 1 from the high-efficiency pump is connected to GND port of controller

Signal cable 2 from the high-efficiency pump is connected to PWM1 port of controller

Signal cable 3 from the high-efficiency pump is not connected to the controller

Some pumps connections are available as above, for example:

Wilo Yonos PARA ST15/7.0 PWM2 M

Grundfos UPM3 SOLAR 15-75 130 CZA

GPA20-8/130 II

i Note:

- 1) High-efficiency pump with 0-10V signal only has 2 signal wires, connected to the corresponding port GND, PWM1 of controller.
- 2) Blue wire not always represent for "GND" and brown wire not always represent for "PWM", "PWM" from pump must be match for "PWM" from controller.
- 3) "GND" from pump must be match for "GND" from controller

4 >0-10V high efficiency pump only has 2 signal cables, connected with GND , PWM1 (PWM2 or PWM3) ports.

4.System introduction

4.1.Overview of the available systems

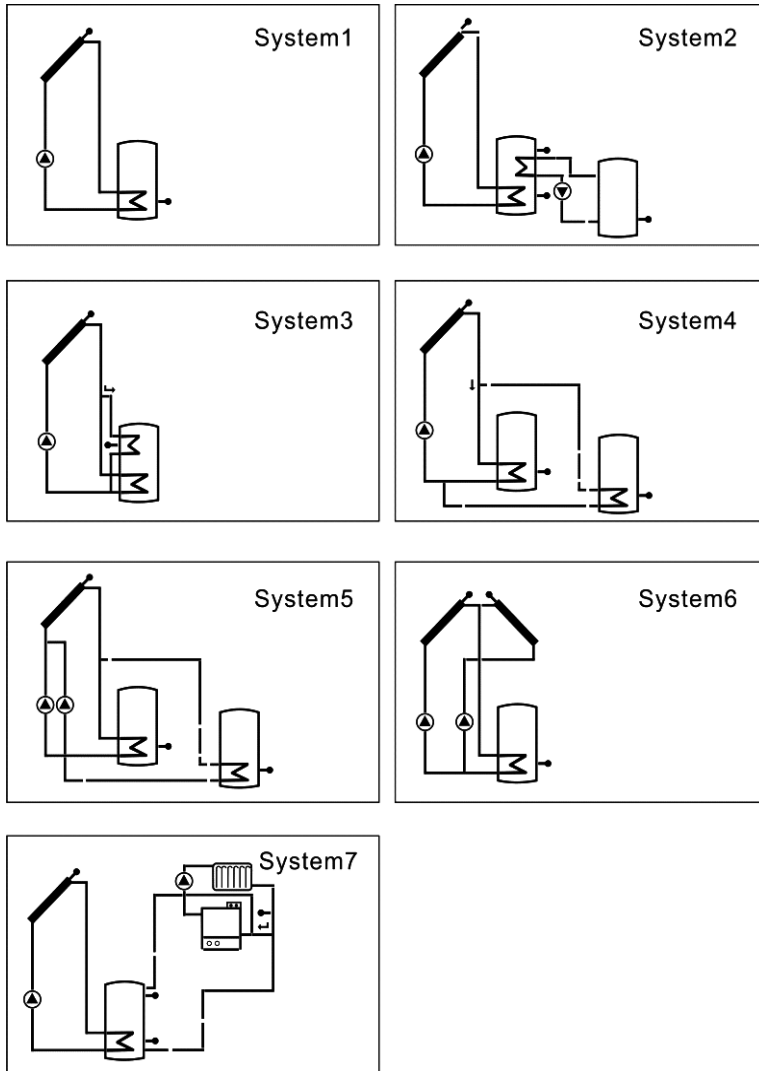

4.2. Description of 7 systems

4.2.1. System 1: Standard solar system with 1 tank, 1 collector field

Description:

The controller calculates the temperature difference between collector sensor T1 and tank sensor T2. If the difference is larger than or identical to the adjusted switch-on temperature difference, the solar circulation pump (R1) will be switched on and the tank will be loaded until the switch-off temperature difference or the maximum tank temperature is reached.

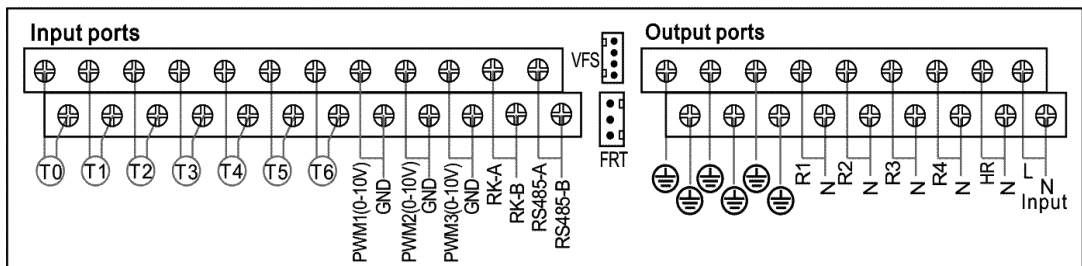
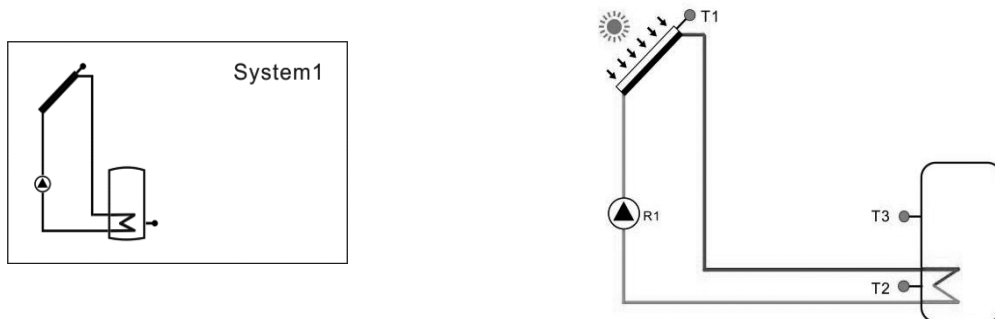

Sensor	Description	Relay	Description
T1	Temperature of collector	R1	Solar circulation pump
T2	Temperature of tank base	HR	Back-up heating
T3	Temperature of tank upper (optional one)		
T5	Return temperature (for thermal energy measurement)		
T6	Flow temperature (for thermal Energy measurement)		

Auxiliary functions

Function code	Function description	Sensor	Relay output
SFB	Solid fuel boiler	T0	R2
AH	Thermostat function	T2/T3 optional	R3(due to R3 output designed for
OPARR	Parallel relay		AH/OPARR function, only one is available)
CIRC	DHW pump circulation (controlled by temperature at preset three time sections / by flow impulse / by three time sections)	T4/ flow switcher (connected on T4 port)	R4(due to R4 output designed for CIRC/OHDP function, only one is available)
OHDP	Thermal transfer -by external radiator		

- 1) When a function in the menu is enabled, multiple systems can be expanded (schematic example by system 1)
- 2) Due to different systems, the extendable functions are not the same (refer to the description of auxiliary functions of System 1-7 for details).

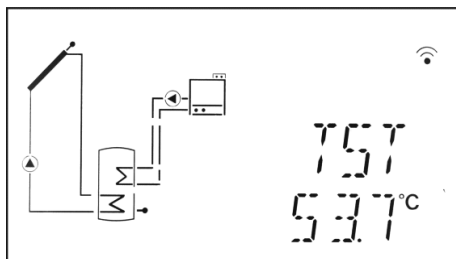

Boiler ON

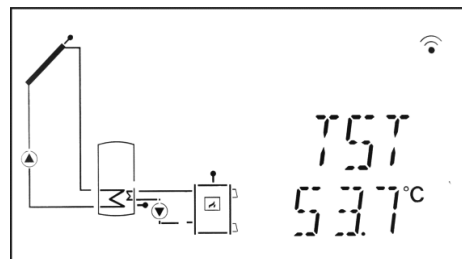

Solid fuel boiler ON (SFB ON)

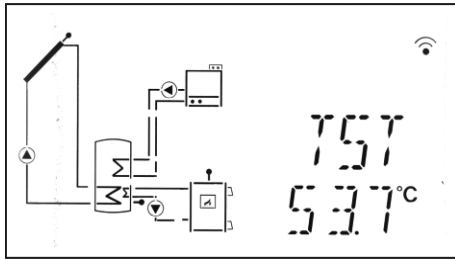

Boiler ON Solid fuel boiler (SFB ON)

Pump logic (OTPUM ON)

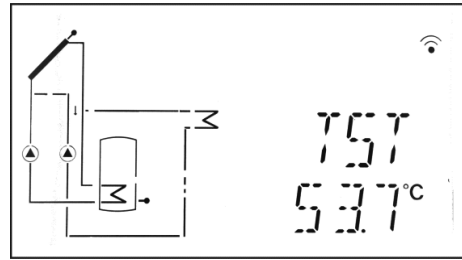

Thermal transfer function (OHDP ON)

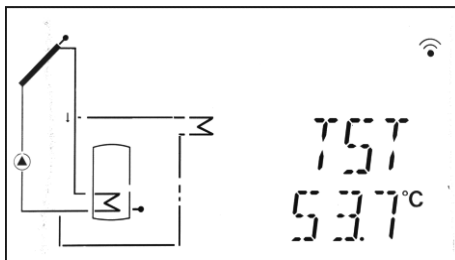

Thermal transfer function (OHDP ON)

Valve logic (OTPUM ON)

4.2.2. System 2: Solar system with 1 collector filed, 2 tanks and thermal energy transferring between 2 tanks

Description:

The controller calculates the temperature difference between collector sensor T1 and tank1 base sensor T2. If the differences is larger than or identical to the adjusted switch-on temperature difference, then the solar circulation pump (R1) will be switched on, tank will be loaded until the switch-off temperature difference or the maximum tank temperature is reached.

Thermal energy transferring means the other tank2 is heated by tank 1, another temperature difference controls the running of pump R2 (temperature difference between T3 and T4 temperature.)

Please refer the paragraph 6.13"HEATX Energy exchange between tanks"

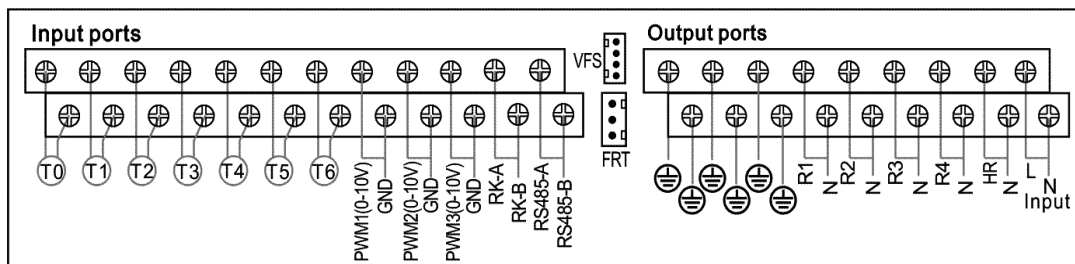
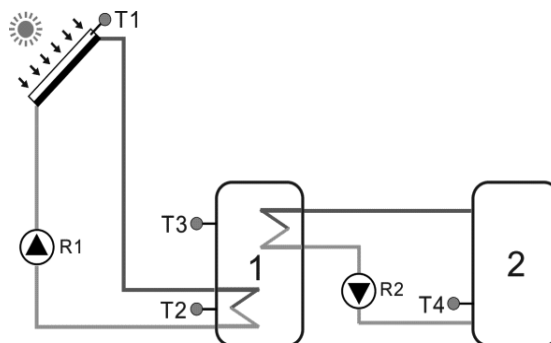
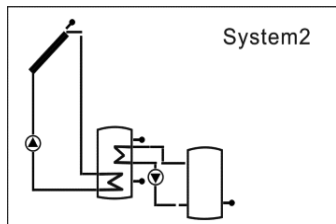

Sensor	Description	Relay	Description
T1	Temperature of collector	R1	Solar circulation pump
T2	Temperature of tank 1 base	R2	Pump for thermal energy transferring between tanks
T3	Temperature of tank 1 upper (optional one)	HR	Back-up heating
T4	Temperature of tank 2		
T5	Return temperature (for thermal energy measurement)		
T6	Flow temperature (for thermal Energy measurement)		

Auxiliary functions

Function code	Function description	Sensor	Relay output
SFB	Solid fuel boiler	T0	R3
AH	Thermostat function	T2/T3 optional	R4 (due to R4 output designed for
OPARR	Parallel relay		AH/OPARR/
CIRC	DHW pump circulation (controlled		CIRC/OHDP

	by temperature at preset three time sections / by flow impulse / by three time sections)		functions, only one is available)
OHDP	Thermal transfer -by external radiator		

4.2.3. System 3: Solar system with 1 collector field, 1 tank, 3-ways valve for tank loading in layers

Description:

The controller calculates the temperature difference between collector sensor T1 and tank base sensor T2 and upper sensor T3. If the difference is larger than or identical to the adjusted switch-on temperature difference, the solar circulation pump (R1) will be switched on, and simultaneously valve R4 turns to the corresponding tank zone and this zone will be loaded until the switch-off temperature difference or the maximum tank temperature is reached.

The priority logic effects prior loading of the upper zone of the tank. Please refer the paragraph 6.11 "LLOGI Tank priority logic"

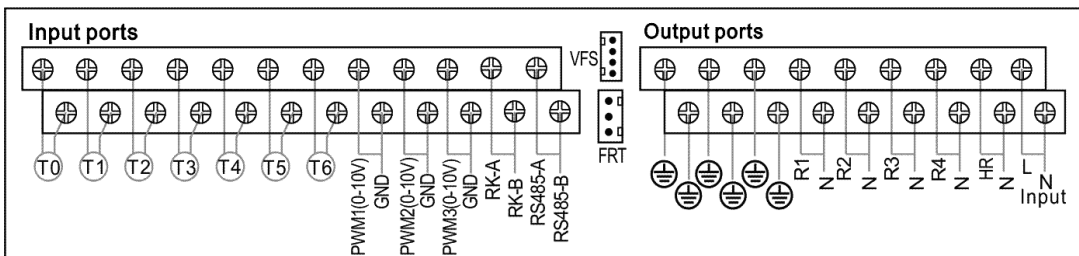
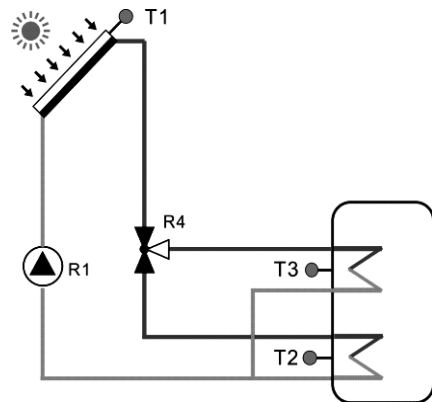
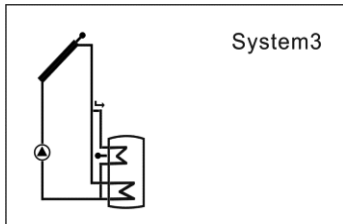

Sensor	Description	Relay	Description
T1	Temperature of collector	R1	Solar circulation pump
T2	Temperature of tank base	R4	Valve for solar circuit
T3	Temperature of tank upper (optional one)	HR	Back-up heating
T5	Return temperature (for thermal energy measurement)		
T6	Flow temperature (for thermal Energy measurement)		

Auxiliary functions

Function code	Function description	Sensor	Relay output
SFB	Solid fuel boiler	T0	R2
AH	Thermostat function	T2/T3 optional	R3 (due to R3 output designed for AH/OPARR/CIRC/OHDP functions, only one is available)
OPARR	Parallel relay		
CIRC	DHW pump circulation (controlled by temperature at preset three time sections / by flow impulse / by three time sections)	T4/ flow switcher (connected on T4 port)	
OHDP	Thermal transfer -by external radiator		

4.2.4. System 4: Solar system with 1 collector field, 2 tanks, valve logic control

Description:

The controller calculates the temperature difference between collector sensor T1 and T2 of tank 1, and T1 and T4 of tank 2. If any difference is larger than or identical to the adjusted switch-on temperature difference, then the solar circulation pump (R1) will be switched on, and simultaneously valve R4 turns to the corresponding tank, and this tank will be loaded until the switch-off temperature difference or the maximum tank temperature is reached.

The priority logic effects prior loading of tank1. Please refer the paragraph 6.11 "LLOGI Tank priority logic"

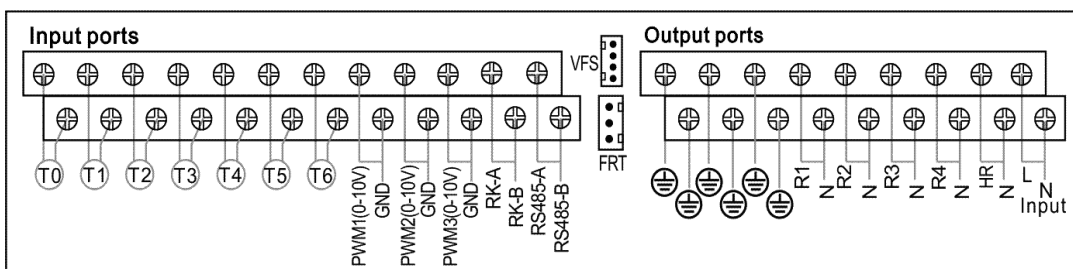
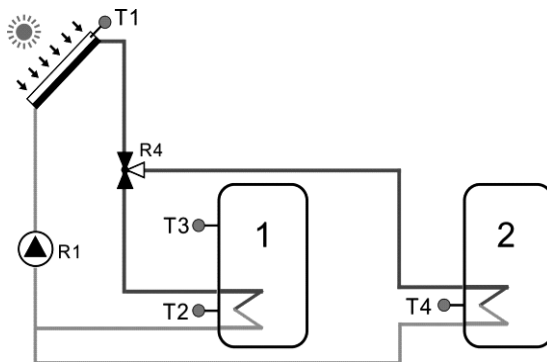
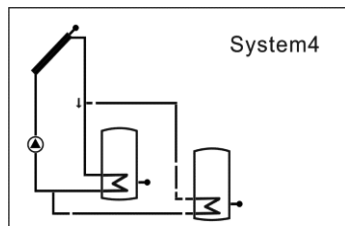

Sensor	Description	Relay	Description
T1	Temperature of collector	R1	Solar circulation pump1
T2	Temperature of tank1 base	R4	Valve for solar circuit
T3	Temperature of tank1 upper (optional one)	HR	Back-up heating
T4	Temperature of tank 2		
T5	Return temperature (for thermal energy measurement)		
T6	Flow temperature (for thermal Energy measurement)		

Auxiliary functions

Function code	Function description	Sensor	Relay output
SFB	Solid fuel boiler	T0	R2
AH	Thermostat function	T2/T3 optional	R3 (due to R3 output designed for)

OPARR	Parallel relay		AH/OPARR/
CIRC	DHW pump circulation (controlled by temperature at preset three time sections / by flow impulse / by three time sections)		CIRC/OHDP functions, only one is available)
OHDP	Thermal transfer -by external radiator		

4.2.5. System 5: Solar system with 1 collector field, 2 tanks, pump - logic control

Description:

The controller calculates the temperature difference between collector sensor T1 and tank 1 and tank 2's base sensor T2 and T4. If any difference is larger than or identical to the adjusted switch-on temperature difference, then the corresponding solar circulation pump (R1 or R2) will be switched on, tank will be loaded until the switch-off temperature difference or the maximum tank temperature is reached.

The priority logic effects prior loading of the tank 1. Please refer the Paragraph 6.11 "LLOGI Tank priority logic"

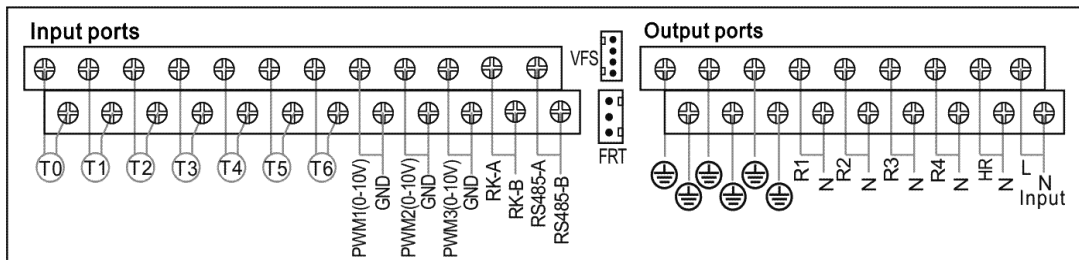
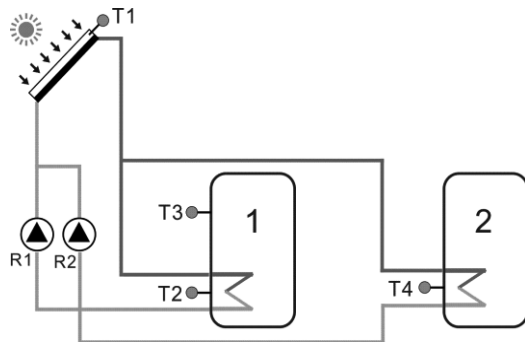
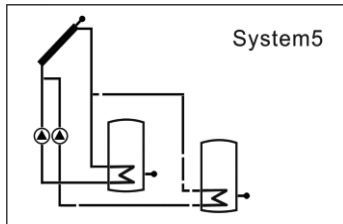

Sensor	Description	Relay	Description
T1	Temperature of collector	R1	Solar circulation pump1
T2	Temperature of tank1 base	R2	Solar circulation pump2
T3	Temperature of tank1 upper (optional one)	HR	Back-up heating
T4	Temperature of tank 2		
T5	Return temperature (for thermal energy measurement)		
T6	Flow temperature (for thermal Energy measurement)		

Auxiliary functions

Function code	Function description	Sensor	Relay output
SFB	Solid fuel boiler	T0	R3
AH	Thermostat function	T2/T3 optional	R4(due to R4 output designed for AH/OPARR/CIRC/OHDP functions, only one is available)
OPARR	Parallel relay		
CIRC	DHW pump circulation (controlled by temperature at preset three time sections / by flow impulse / by three time sections)		
OHDP	Thermal transfer -by external radiator		

4.2.6. System 6: Solar system with east/west collector fields, 1 tank

Description:

The controller calculates the temperature difference between east/ west collector sensor T1 and T0 and tank base sensor T2. If any difference is larger than or identical to the adjusted switch-on temperature difference, then solar circulation pump (R1 or R2) will be switched on, and tank will be loaded until the switch-off temperature difference or the maximum tank temperature is reached.

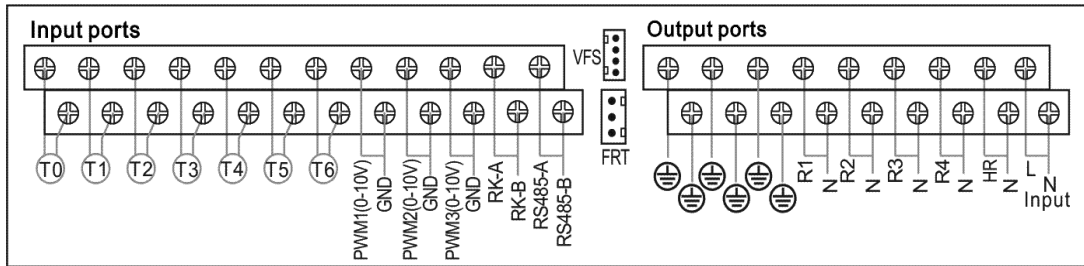
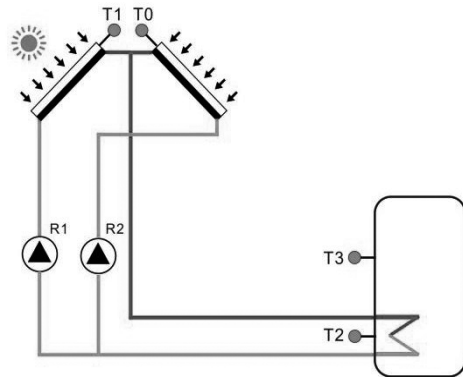
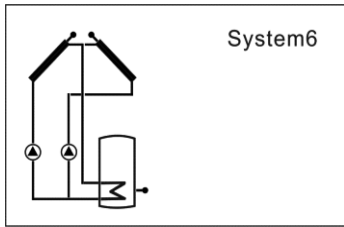

Sensor	Description	Relay	Description
T0	Temperature of collector 2	R1	Solar circulation pump1
T1	Temperature of collector 1	R2	Solar circulation pump2
T2	Temperature of tank base	HR	Back-up heating
T3	Temperature of tank upper (optional one)		
T5	Return temperature (for thermal energy measurement)		
T6	Flow temperature (for thermal Energy measurement)		

Auxiliary functions

Function code	Function description	Sensor	Relay output
SFB	Solid fuel boiler	T0	R3
AH	Thermostat function	T2/T3 optional	R4(due to R4 output designed for
OPARR	Parallel relay		AH/OPARR/
CIRC	DHW pump circulation (controlled		CIRC/OHDP

	by temperature at preset three time sections / by flow impulse / by three time sections)		functions, only one is available)
OHPD	Thermal transfer -by external radiator		

4.2.7. System 7: Solar system with 1 collector field, 1 tank, loading the heating return

Description:

The controller calculates the temperature difference between collector sensor T1 and tank sensor T2. If the difference is larger than or identical to the adjusted switch-on temperature difference, then solar circulation pump (R1) will be switched on, and this tank will be loaded until the switch-off temperature difference or the maximum tank temperature is reached.

By using another temperature difference between T3 and T0 controls valve R4 to load the heating return flow. Please refer the Paragraph 6.14 "RPH Heating return pipe preheat"

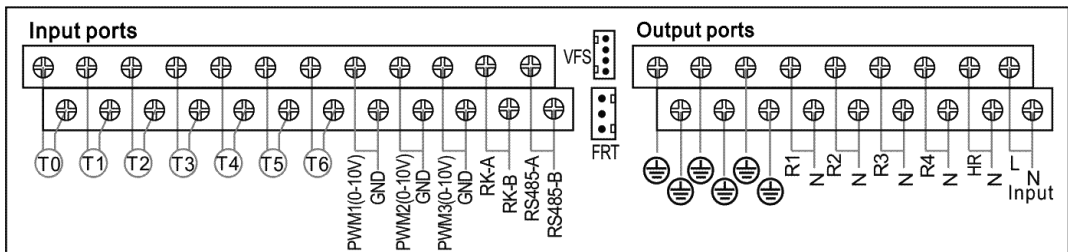
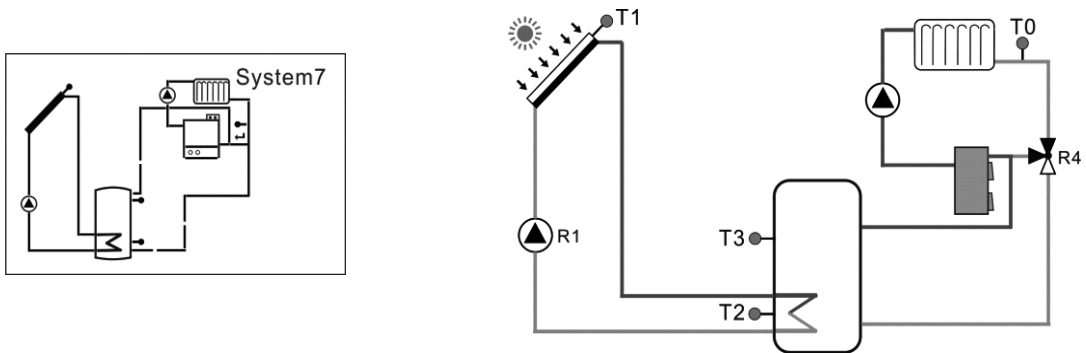

Sensor	Description	Relay	Description
T0	Temperature of heating return	R1	Solar circulation pump
T1	Temperature of collector	R4	Valve for heating return
T2	Temperature of tank base	HR	Back-up heating

T3	Temperature of tank upper (optional one)		
T5	Return temperature (for thermal energy measurement)		
T6	Flow temperature (for thermal Energy measurement)		

Auxiliary functions

Function code	Function description	Sensor	Relay output
AH	Thermostat function	T2/T3 optional	R2 (due to R2 output designed for
OPARR	Parallel relay		AH/OPARR functions, only one is available)
CIRC	DHW pump circulation (controlled by temperature at preset three time sections / by flow impulse / by three time sections)	T4/ flow switcher (connected on T4 port)	R3 (due to R3 output designed for
OHDP	Thermal transfer -by external radiator		CIRC/OHDP functions, only one is available)

4.3.Commissioning

Before connecting the controller to the mains, ensure system is filled and ready for operation, please connecting all sensors to the input terminals, pumps or valves to the output terminals and fill the system.

After power is switched on, the controller runs an initialization phase for 5 seconds, then controller runs a commissioning menu, it leads the user through the most important adjustment, you can setup time, password and system type and its related parameters for running system.

5.Functions and options

5.1.Overview of menu structure

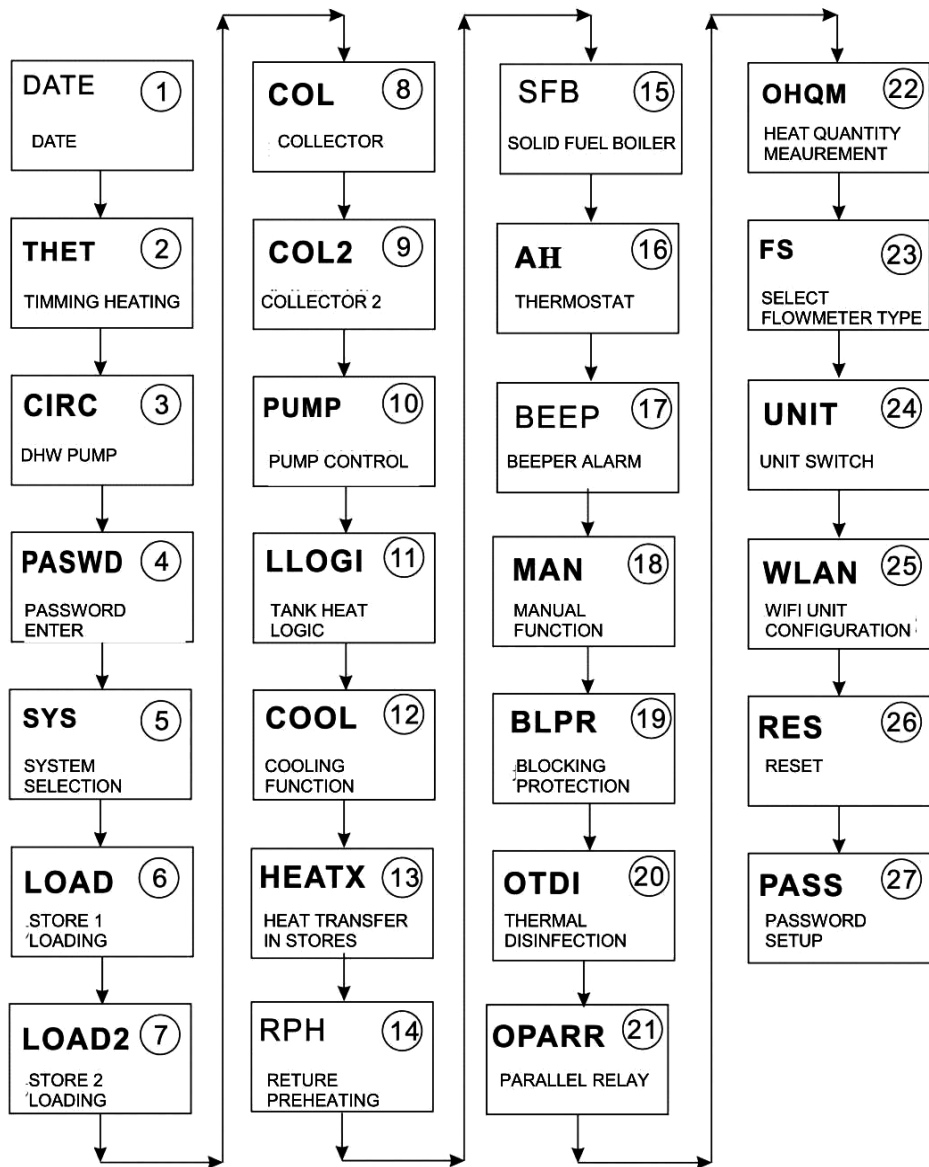

5.2.Menu operation description

- Access main menu
- ▶ Press “SET” key to access main menu
- ▶ Press “↑”, “↓” to select menu
- ▶ Press “SET” key to enter the sub-menu

- Access sub-menu

- ▶ Press “SET” key to access sub-menu
- ▶ Press “↑”, “↓” key to select sub-menu to be adjusted
- ▶ Press “SET” key to enter this sub-menu
- ▶ Press “SET” button, “OFF” or “ON” blinks on the screen
- ▶ Press “↑”, “↓” button, select “ON” to trigger the menu, or select “OFF” to close the menu
- ▶ Press “SET” or “ESC” button, to confirm the selection
- ▶ Press “↑” key to access the next sub-menu
- ▶ Press “SET” key to access value adjust
- ▶ Press “↑”, “↓” key to adjust value
- ▶ Press “SET” or “ESC” button, to confirm the value
- ▶ Press “ESC” to exit the menu.



Note: after entering the menu adjustment interface, if you don't press any key within 5 minutes, screen will exit the adjustment ,and return to the main interface.

5.3.Check value

At the normal operation mode, press “↑”, “↓” button, you can view the temperature of collector and tank, temperature of Grundfos sensor (TVFS), pump speed (n%), accumulated pump running time (hR),current thermal energy (DKWH), accumulated thermal energy (KWh /MWh), flow rate (L/M), controller running time (DAYS), software version (SW),Year/Month/Day, time (TIME).

Under standby status, press “SET” key for 3 seconds, then press “↑”, “↓” key to check the type of pump and unblock function.



Note:

- 1) Only after the corresponding function is enabled, the function information just can be displayed and checked.
- 2) Enter the value checking interface, if you don't press any key within 5 minutes, screen will exit the adjustment and return to the main interface.

5.4.Shortcut trigger function of back-up heating, circuit pump and WiFi reset information

- 1) Under standby status, “ESC” key for 3 seconds, it is possible to manual trigger on the circuit pump

(R1), after fifteen minutes or re the “ESC” key for 3 seconds, then circuit pump is stopped.

2) Under standby status, press “↓” for 3 seconds, manual back-up heating is triggered. press “↑”, “↓” key to adjust the temperature set point, press “ESC” key to confirm the parameter and trigger back-up heating, when the set point of temperature reaches, manual heating is stopped. During the period of manual heating process, repress “↓” for 3 seconds, to switch-off manual heating immediately.(this function is only available when the back-up heating THET function is enabled).

3) Under standby status, press “↑” for 3 seconds, controller will automatically repeat to configure WiFi module (WiFi indication lighter blinks, WiFi icon displayed on screen and blinks)

6.Menu function and parameter set (for user)

6.1.Date(Time/ Date set)

Function description:

ADST: Switch on/off the summer time function

When you deactivate the “summer time function”, controller is possible to still run, “ADST” is only referring directives Europe 200/84/EG, only suitable for Europe union country.

i Note: In the case power to controller is switched-off, date and time will be remembered in controller for 36 hours.

Menu structure						
<pre> graph TD DATE["DATE (Main menu) ①"] --> TIME["TIME"] TIME --> ADST["ADST"] ADST --> YYYY["YYYY"] YYYY --> MMDD["MM/DD"] </pre>						
Main menu	Submenu 1	Submenu 2	Default set	Adjust range	Adjust step	Description
DATE						Time/date setup
	TIME					Hour/minute

	ADST		OFF	ON/OFF		Summer time on/off
	YYYY					Year
	MM/DD					Month/day

Function setup:

- ▶ Press “SET” button, select DATE menu
- ▶ Press “SET” button, “TIME 00:00” displays on the screen
- ▶ Press “SET” button, time zone hour “00” blinks
- ▶ Press “↑”, “↓” key to adjust hour time
- ▶ Press “SET” button, time zone minute “00” blinks
- ▶ Press “↑”, “↓” key to adjust minute time
- ▶ Press “SET” or “ESC” button, to confirm the setting



- ▶ Press “↑”button, “ADST OFF” displays on the screen (summer time)
- ▶ Press “SET” button, “OFF” blinks
- ▶ Press “↑”, “↓” key to activate summer timer function
- ▶ Press “SET” or “ESC” button, to confirm the setting



- ▶ Press “↑”button, “YYYY 2015” displays on the screen, adjust year.
- ▶ Press “SET” button, “2015” blinks
- ▶ Press “↑”, “↓” key to adjust year
- ▶ Press “SET” or “ESC” button, to confirm the setting



- ▶ Press “↑”button, “MM 01” displays on the screen, adjust month.
- ▶ Press “SET” button, “01” blinks
- ▶ Press “↑”, “↓” key to adjust month
- ▶ Press “SET” or “ESC” button, to confirm the setting



- ▶ Press “↑”button, “DD 01” displays on the screen, adjust day.
- ▶ Press “SET” button, “01” blinks
- ▶ Press “↑”, “↓” key to adjust day
- ▶ Press “SET” or “ESC” button, to confirm the setting

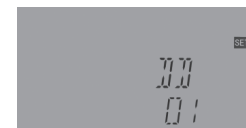

6.2.THET Timed back-up heating

Function description: Timed heating

An electrical back-up heater is possible to be installed in a solar system, controller can provide automatic thermostat control function, when tank temperature T2/T3 drops below the preset switch – on temperature of this function, electrical heater(HR) will be triggered and when tank temperature T2 rises to the preset switch-off temperature, electrical heater(HR) is stopped.

- Two kinds of heating device(heating mode) are available:

- 1) Electrical heater as back-up heat resource (ELET)
- 2) Boiler as back-up heat resource (BOIL)

 Note: In system 2/4/5, it is possible to select only one as heat resource between boiler backup heating (BOIL) and solid fuel boiler (SFB).

- Three time - sections can be set for back-up heater

Factory default set:

- 1) The first time - section of heating starts at 04:00 and stops at 05:00 a.m.
- 2) The second time - section of heating starts at 10:00 and stops at 10:00 a.m.
- 3) The third time - section of heating starts at 17:00 and stops at 22:00 p.m.

For all time - sections, default temperature for control back-up heating is triggered at temperature of 40°C, and stopped at temperature of 50°C.

If it is needed to deactivate the back-up heating function in one time - section, then just set the start time and stop time with a same value, for example, for the second-time - section, the start time is 10:00 a.m, and the stop time is also 10:00 a.m.

Within three time - sections, the adjust range of the switch-on temperature is 0°C~(OFF-2°C), and the switch-off temperature is (ON+2°C) ~95°C.

- SMT Intelligent heating

At the case that solar energy is insufficient to heat the tank, to ensure user has sufficient hot water, controller will check the temperature of tank automatically at the preset time, if tank's temperature is not reached to the desired temperature, then back-up heating device will be triggered, and when tank's temperature rises to the desired value, then back-up heat device is stopped.

Factory set(not adjustable) of SMT function:

Default at 13:00 of the first time to trigger the back-up heat device to heat tank to 30°C.

Default at 14:00 of the second time to trigger the back-up heat device to heat tank to 35 °C.

Default at 15:00 of the third time to trigger the back-up heat device to heat tank to 40°C.
 Default at 16:00 of the fourth time to trigger the back-up heat device to heat tank to 45 °C.
 Default at 17:00 of the fifth time to trigger the back-up heat device to heat tank to 50 °C.

- Diagram of back-up boiler connection (BOIL)

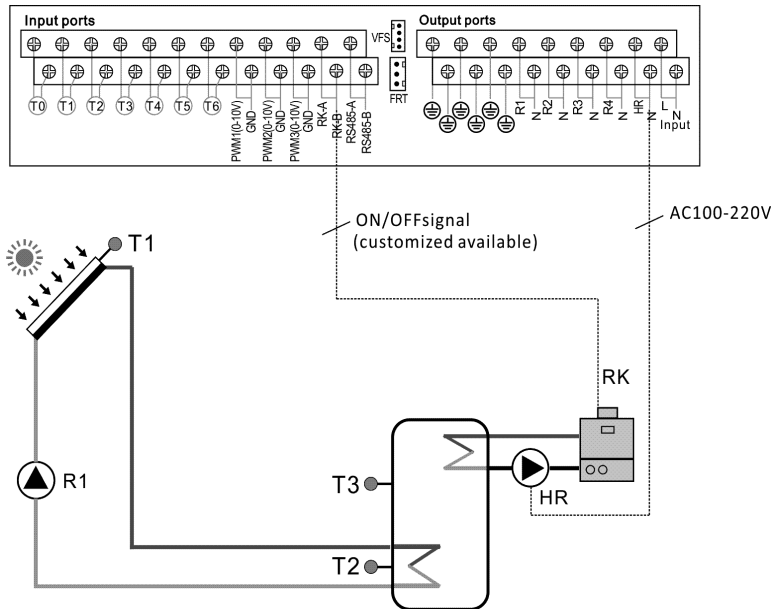

If boiler is selected as back-up heat device, output RK and HR is controlled by T2 or T3 (optional). When T2 or T3 (optional) is reached to the switch-on temperature of back-up heating function, then back-up heating output relay (RK and HR) are triggered, when T2 or T3 (Optional) is exceeded the switch-off temperature of back-up heating function, then back-up heating output RK and HR are closed.

i Note: if electrical heater is selected as back-up heater, then according to the power of the heater, an appropriate AC contactor and a safety protection device should be installed, we recommend installing the accessory “SR802” (see accessories in paragraph10)

Menu structure

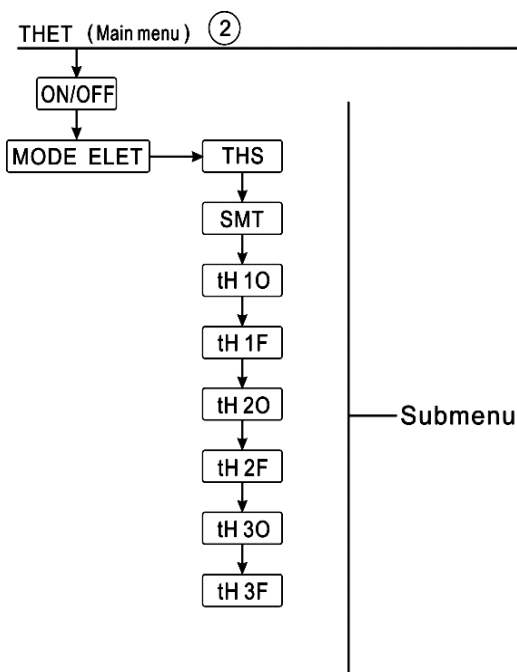

Main menu	Submenu 1	Submenu 2	Default set	Adjust range	Adjust step
THET			OFF	ON/OFF	Timed heating function
	MODE		ELET	ELET / BOIL	back-up heat resource selection between electrical heater/boiler
		THS	T2	T2, T3	Selection of the target sensor for timed heating function
		SMT	OFF	ON/OFF	Intelligent heating
		tH10	04:00/40°C	00:00-23:59/0.0-93°C	Start time and switch-on temperature for the first time-section
		tH1F	05:00/50°C	00:00-23:59/2-95°C	Close time and switch-off temperature for the first time-section
		t H20	10:00/40°C	00:00-23:59/0.0-93°C	Start time and switch-on

					temperature for the second time - section
		tH2F	10:00/50°C	00:00-23:59/2-95°C	Close time and switch-off temperature for the second time - section
		tH3O	17:00/50°C	00:00-23:59/0.0-93°C	Start time and switch-on temperature for the third time-section
		tH3F	22:00/55°C	00:00-23:59/2-95°C	Close time and switch-off temperature for the third time-section

Function set:

▶ Press “SET” button, access main menu, press “↑”key to select THET timed heating menu

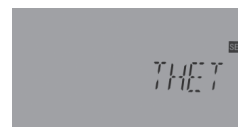

▶ Press “SET” button, “THETOFF” displays

▶ Press “SET” button, “OFF” blinks

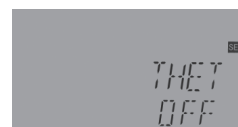

▶ Press “↑”, “↓” key to activate the function, “THET ON” displays on the screen

▶ Press “SET” or “ESC” button, to confirm the setting

▶ Press “↑”, “MODE ELET” displays on the screen, select the heating source.

▶ Press “SET” button, “ELET” blinks on the screen.



▶ Press “↑”, “↓” key to select heating source.

▶ Press “SET” or “ESC” button, to confirm the setting

▶ Press “↑”, to select the sensor for heating function, “THS T2” displays on the screen

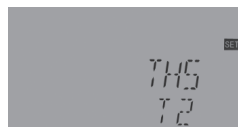

▶ Press “SET” button, “T2” blinks

▶ Press “↑”, “↓” key to select the available sensor

▶ Press “SET” or “ESC” button, to confirm the setting

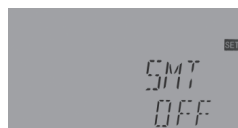

▶ Press “↑”, to access the intelligent heating window, “SMTOFF” displays on

the screen

▶ Press “SET” button, “OFF” blinks

▶ Press “↑”, “↓” key to activate the intelligent heating function, “SMT ON”

displays on the screen

▶ Press “SET” or “ESC” button, to confirm the setting



▶ Press “↑”, to access the window of the start time and switch-on

temperature setting of heating in the first-time - section, “tH1O 04:00” displays

on the screen

▶ Press “SET” button, hour time zone “04” blinks

▶ Press “↑”, “↓” key to set the hour of the start time of heating in the first-time -

section

▶ Press “SET” button, minute time zone “00” blinks

▶ Press “↑”, “↓” key to set the minute of the start time of heating in the first-time

- section

▶ Press “↑”, to access the switch-on temperature of heating in the first-time - section, “tH1O 40 °C”

displays on the screen

▶ Press “SET” button, temperature “40 °C” blinks

▶ Press “↑”, “↓” key to adjust the switch-on temperature of heating in the first-time - section

▶ Press “SET” or “ESC” button, to confirm the setting

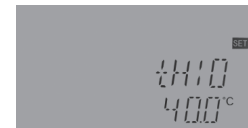

▶ Press “↑”, to access the window of the close time and switch-off temperature setting of heating in the first-time - section, “tH1F 05:00” displays on the screen

▶ Press “SET” button, hour time zone “05” blinks

▶ Press “↑”, “↓” key to set the hour of the close time of heating in the first-time -

section

▶ Press “SET” button, minute time zone “00” blinks

▶ Press “↑”, “↓” key to set the minute of the close time of heating in the

first-time - section

▶ Press “↑”, to access the switch-off temperature of heating in the first-time -

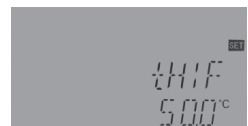

section, “tH1F 50 °C” displays on the screen

▶ Press “SET” button, temperature “50°C” blinks



- ▶ Press “↑”, “↓” key to adjust the switch-off temperature of heating in the first-time - section
- ▶ Press “SET” or “ESC” button, to confirm the setting
- ▶ Press “↑”, to access the window of the start time and switch-on temperature setting for back-up heating in the second time - section, same steps like above description to set the parameters for second and third time - sections.



Note: When the icon  displayed on the screen, it indicates the timed heating function (electrical heater) is enabled, when icon  flashes on the screen, it indicates the heating running.

6.3.CIRC DHW circuit pump controlled by temperature in three time - sections / flow switcher and by three time sections

Function description:

This function is designed to get warm water quickly when customer open the stopcock. In the case stopcock is closed, hot water pipe is also used as the circuit pipe.

Three hot water circuit supply modes are available:

- 1) Timed temperature controlled mode TEMP
- 2) Timed flow switcher controlled mode CYFS
- 3) Time controlled mode TIME

For using this function, an extra circuit pump RX and a flow switcher or a temperature sensor (mounted on the hot water return pipe (TX) should be installed in the system. (and due to the solar system difference, output relay or sensor input used for circuit pump RX and temperature sensor TX may be different also, see detailed in paragraph 4.2)

DHW pump has three controlling modes : Timed temperature controlled mode TEMP, Timed flow switcher controlled mode CYFS, Time controlled mode TIME, only one mode can be activated. And parameter adjusting step is same.



Displayed on the screen, it indicates Timed temperature controlled mode is enabled, this icon flashes, it indicates DHW pump is running.



Displayed on the screen, it indicates Timed flow switcher controlled mode is enabled, this icon

quickly flashes, it indicates DHW pump is running.

 Displayed on the screen, it indicates Timed controlled mode is enabled, this icon flashes slowly, it indicates DHW pump is running.

 Note:

- 1) If one of auxiliary function is using temperature sensor T4, then only timed control DHW pump mode can be enabled.
- 2) due to the system selection, in one system, several auxiliary functions may be allocated to the same output, for example to R2 output, (see paragraph 4.2 system diagram and its auxiliary functions), then only one function can be activated, other functions are deactivated automatically, and its function displays “NONE”.
- 3) And due to system selection, the sensor and relay for a same function may be different.

- Three time - sections/ temperature control mode TEMP

Within the time - section (default: DHW temperature is less than 40°C (CYCO) , DHW circuit pump is trigger, when temperature rises to 45°C (CYCF) , DHW circuit pump is stopped).

Trigger on conditions of temperature controlled DHW circuit pump (STAT): when tank temperature (from sensor which is designed for the tank maximum temperature SMAXS) is 2 °C higher than the preset switch-off temperature (CYCF) of this function, DHW pump just can be triggered.

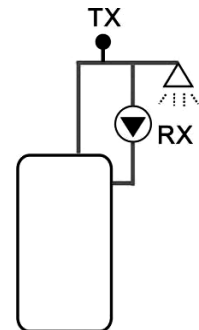

Default time - section set:

The first time - section: start at 05:00 and stops at 07:00a.m

The second time - section: starts at 11:00 and stops at 13:00

The third time - section: starts at 17:00 and stops at 22:00 p.m.

- Three time - sections/ flow switcher control mode CYCFS

Function description:

Open the stopcock, water flows through pipe, a flow signal is

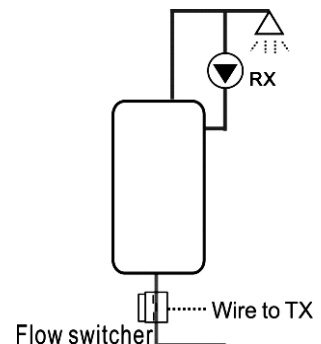

detected by a flow switcher which is mounted on the cold-water pipe and sent to the controller, and then controller will trigger the DHW circuit pump (RX) and it pumps hot water from tank to the circuit pipe. The running time of circuit pump is adjustable, when the preset time runs out, pump stops.

This stopcock seems like a remote controller to control the running of circuit pump. This operation mode is an environment-friendly, energy-saving control solution.

Open the stopcock for a shortly time, the flow switcher which is mounted on the cold flow pipe of tank will feel the flow signal, and then controller will trigger the circuit pump RX, and pump will feed hot water from tank to the pipe. Then when you re-open the stopcock, hot water flows out immediately. Once the pump's running time finishes, then pump is stopped. When hot water is not used, to avoid the heat releasing through pipe due to the running of circuit pump, controller will stop the pump after the pre-set running time. To avoid the pump being re-triggered just after it stopped, parameter "rest time" is used for this control.

Open the stopcock within a pre-set time - section, pump running as the default design: pump running for every three minutes and then rest for 15minutes (the adjustable range of the running time is 1-30 MIN and the rest time is 0-60MIN)



Note:

- 1) Installed a check valve on the inlet pipe of circuit pump to avoid the water which is from tank mixing with water from circuit pipe.
- 2) If the parameter stop time (CYCF) is set with value 0 minute, then when flow switcher feels the flow and thus to trigger the pump, pump will run for the whole time - section. And when the stopcock is closed, pump is stopped automatically.

Default time - section set:

The first time - section: start at 05:00 and stops at 07:00a.m

The second time - section: starts at 11:00 and stops at 13:00

The third time - section: starts at 17:00 and stops at 22:00 p.m

- Flow switcher fitting:

Material of fitting: brass

House: plastic

Connection: G3/4

Reed of flow switch: Max 300V DC/1A



i Note:

- 1) Note the flow direction indicated on the flow switcher!
- 2) Lead the wires from flow switcher to input ports of controller, no polarity required.
- 3) Flow switcher is not included in the delivery list of this controller, please buy it separately.

- Time Three time - sections/ time control mode

Function description:

Within a time section, factory set DHW pump running for 3 minutes(adjustable 1-30minute) , and then stops for 15 minutes, repeat running. If the stop time (CYCF) is set as 0 minute, then within time section , pump runs for the duration of the timed period.

Default time - section set:

- 1) The first time - section: start at 05:00 and stops at 07:00a.m, running for 3 minutes, stop for 15 minutes.
- 2) The second time - section: starts at 11:00 and stops at 13:00,running for 3 minutes, stop for 15 minutes.
- 3) The third time - section: starts at 17:00 and stops at 22:00 p.m. running for 3 minutes, stop for 15 minutes.

Menu structure

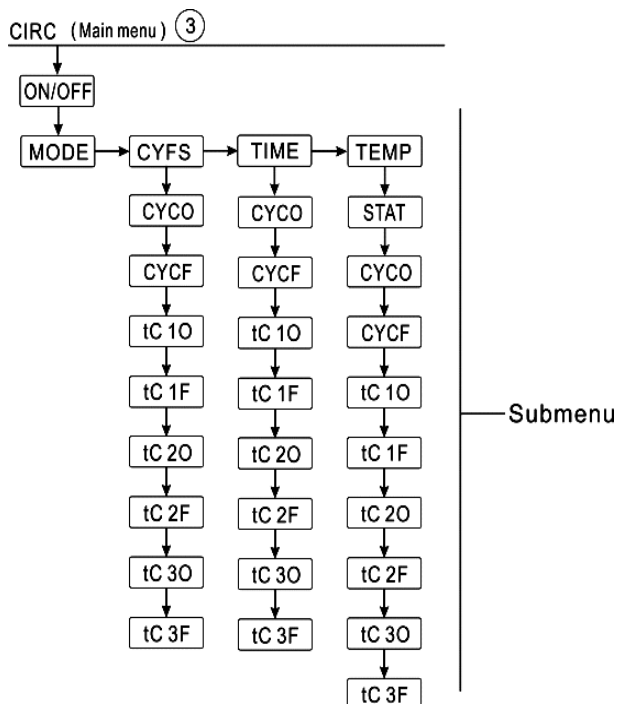

Main menu	Submenu 1	Submenu 2	Default set	Adjust range	Adjust step	Description
CIRC			OFF	ON/OFF		DHW circuit function
	MODE		CYFS	CYFS /TIME/TEMP		Control mode selection Temperature control the DHW circuit pump/ Flow control the DHW circuit pump/ Time control DHW circuit pump
		STAT	ON	ON/OFF		Trigger condition of temperature control the DHW circuit pump: Tank temperature (from the sensor which is defined for tank maximum temperature SMAXS) is 2°C higher than

						the switch-off temperature
		CYCO	40°C /3min	5-53°C/1-30min	0.5°C/1min	Switch-on temperature or running time
		CYCF	45°C /15min	7-55°C/0-60min	0.5°C/1min	Switch-off temperature or the rest time
		t C1O	05:00	00:00-23:59		Start time of the first time-section
		t C1F	07:00	00:00-23:59		Close time of the first time-section
		t C2O	11:00	00:00-23:59		Start time of the second time-section
		t C2F	13:00	00:00-23:59		Close time of the second time-section
		t C3O	17:00	00:00-23:59		Start time of the third time-section
		t C3F	22:00	00:00-23:59		Close time of the third time-section

Function set: (take DHW three time - sections temperature control mode as example)



- ▶ Press “SET” button, select main menu CIRC
- ▶ Press “SET” button, “CIRC ” displays on the screen
- ▶ Press “SET” button, “CIRC OFF” displays
- ▶ Press “SET” button, “OFF” blinks
- ▶ Press “↑”, “↓” key to activate the function, “CIRC ON” displays on the screen



- ▶ Press “SET” or “ESC” button, to confirm the setting
- ▶ Press “↑”, “MODE CYFS” displays on the screen (three time - sections temperature control)
- ▶ Press “SET” button, “CYFS” blinks
- ▶ Press “↑”, “↓” key to activate time controlled DHW circuit mode
- ▶ Press “SET” or “ESC” button, to confirm the setting



▶ Press “↑”, “STAT ON” displays on the screen (condition of pump trigger -on, only available at three time - sections temperature control mode)

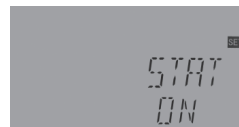

▶ Press “SET” button, “ON” blinks (default set is ON, activate this function)

▶ Press “↑”, “↓” key to deactivate the function, “STAT OFF” displays on the screen

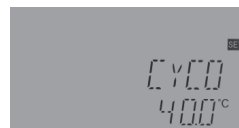

▶ Press “SET” or “ESC” button, to confirm the setting

▶ Press “↑”, “CYCO 40°C” displays on the screen, to set the trigger on temperature of DHW pump (if flow control mode or time control mode, then here displays “CYCO 03Min”, here take temperature as example)

▶ Press “SET” button, “40°C” blinks

▶ Press “↑”, “↓” key to adjust the switch-on temperature of DHW circuit pump, adjustable range 0°C ~ (OFF-2 °C)

▶ Press “SET” or “ESC” button, to confirm the setting

▶ Press “↑”, “CYCF 45 °C” displays on the screen (switch off temperature for DHW circuit pump)



▶ Press “SET” button, “45 °C” blinks

▶ Press “↑”, “↓” key to adjust the switch-off temperature of DHW circuit pump, adjustable range (ON+2°C) ~55°C

▶ Press “SET” or “ESC” button, to confirm the setting

▶ Press “↑”, “tC10 05:00” displays on the screen, to set the start time of the first time-section.

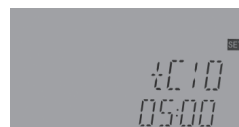

▶ Press “SET” button, hour time “05” blinks

▶ Press “↑”, “↓” key to adjust time hour of the start time of the first time-section

▶ Press “SET” button, minute time “00” blinks

▶ Press “↑”, “↓” key to adjust time minute of the start time of the first time-section

▶ Press “SET” or “ESC” button, to confirm the setting

▶ Press “↑”, to access the window of the close time of heating in the first-time - section, “tH1F 07:00” displays on the screen

▶ Press “SET” button, hour time zone “07” blinks

▶ Press “↑”, “↓” key to set the hour of the close time of heating in the first-time - section

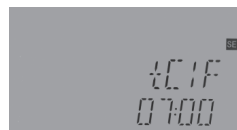

▶ Press “SET” button, minute time zone “00” blinks

▶ Press “↑”, “↓” key to set the minute of the close time of heating in the first-time - section

▶ Press “SET” or “ESC” button, to confirm the setting

▶ Press “↑”, to access the window of the start time and close time setting for back-up heating in the second time - section, same steps like above description to set the parameters for second and third time - sections.

If it is needed to close one time - section, then just set the start time and close time with a same time. (example: at 10:00 start circuit, and at 10:00 close the circuit)

Function operation and parameter setting (expertise)

6.4.PRSWD Password

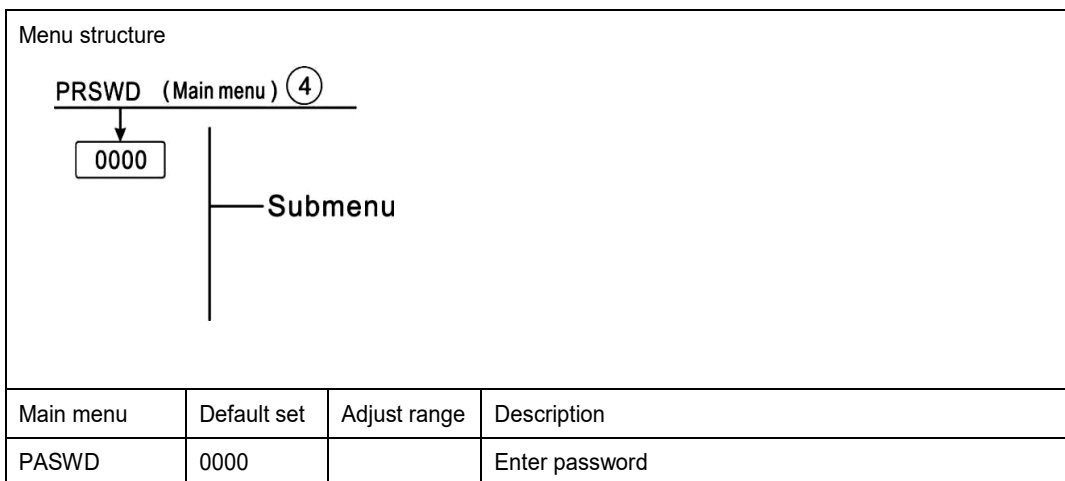

Function set:

▶ Press” SET” key access the main menu, press “↑” and select “PRSWD

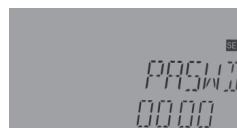

0000”.

▶ Press “SET” button, the left first digital blinks to ask for entering the password, default password is “0000”

▶ Press “↑”, “↓” key to enter the first digital

▶ Press “SET” button, the second digital blinks

▶ Press “↑”, “↓” key to enter the second digital

▶ Press “SET” button, the third digital blinks

▶ Press “↑”, “↓” key to enter the third digital

▶ Press “SET” button, the forth digital blinks

▶ Press “↑”, “↓” key to enter the forth digital

▶ Press “SET” to access the main menu

Through the password to limit the right of customers to set some important parameters, and four digital are required to enter, default password is “0000”.

If no password is reset, then please press “SET” five times to access main menu directly.

6.5.SYS system selection

For every system, there are many pre-programmed options and setting, they can be activated or adjusted according the system requirement. 7 systems are available to be selected in this controller.

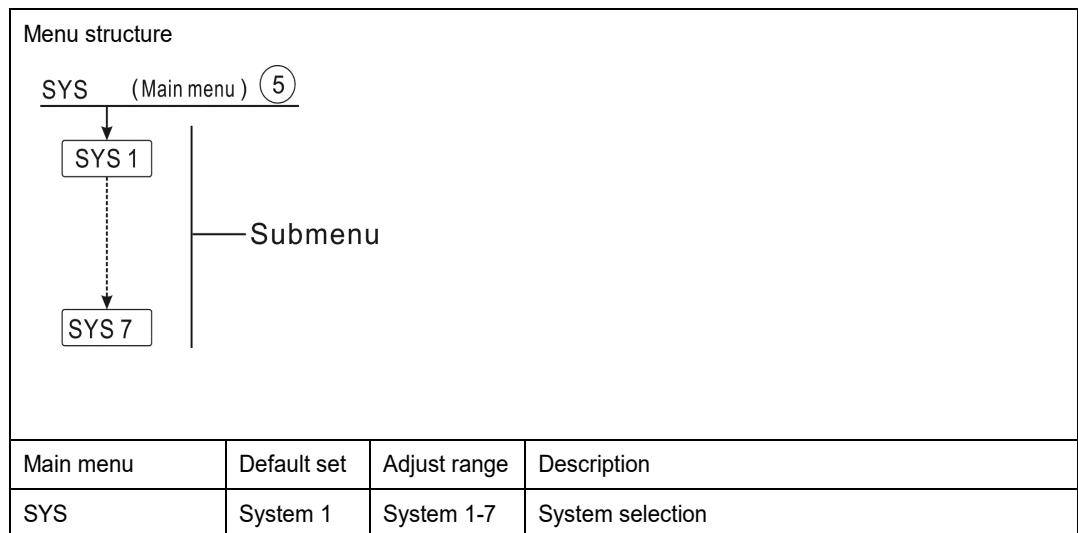

Function set:

- ▶ Press “SET” key to select main menu “SYS”
- ▶ Press “SET” button, “SYS 1” displays on the screen
- ▶ Press “SET” button, “1” blinks
- ▶ Press “↑”, “↓” key to select system
- ▶ Press “SET” or “ESC” button, to confirm the setting

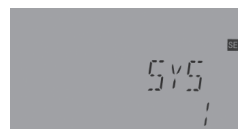
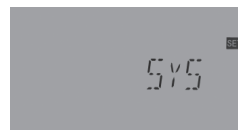

6.6 ./ 6.7. LOAD/LOAD2 Tank heating set

Function description:

- ΔT DT Temperature difference

The controller works with a standard differential control logic. If the temperature reaches or exceeds the switch-on temperature difference (DTO), the pump switches on. When the temperature difference reaches or falls below the adjusted switch-off temperature difference (DTF), the respective relay switches off.

 Note:

- 1) The switch-on temperature difference must be 0.5K higher than the switch-off temperature difference. The set temperature difference must be at least 0.5K higher than the switch-on temperature difference.
- 2) In systems with 2 tanks or tank loading in layers, 2 separate menus (LOAD and LOAD 2) will be displayed.

- Speed control

If the temperature reaches or exceeds the switch-on temperature difference, the pump is switched on and will run at 100% speed for 10s. Then, the speed is reduced to the minimum pump speed value.

If the temperature difference reaches the set temperature difference DTS, the pump speed increases by one step (10%). The response of the controller can be adapted via the parameter RIS. If the difference increases by the adjustable rise value RIS, the pump speed increases by 10% until the maximum pump speed of 100% is reached. If the temperature difference decreases by the adjustable rise value RIS, pump speed will be decreased by one step 10%.

i Note: To enable speed control function, the corresponding pump should be set to (MIN, MAX) and relay control should be set to (PULS, PSOL, PHEA or 0-10 V) (under menu PUMP).

SMAX Maximum tank temperature protection set

If the tank temperature reaches the pre-set maximum temperature, the tank will no longer be loaded to avoid damage caused by overheating. If the maximum tank temperature is exceeded, icon  is displayed and code SMX displays.

The sensor for tank maximum limitation (SMAXS) can be selected. The maximum limitation always refers to the sensor selected. The switch-on hysteresis (HYST) can be set. Default is 2 °C, for example, when tank maximum temperature is set to 70°C, then at 68 °C, Maximum tank temperature protection function is deactivated automatically.

Menu structure

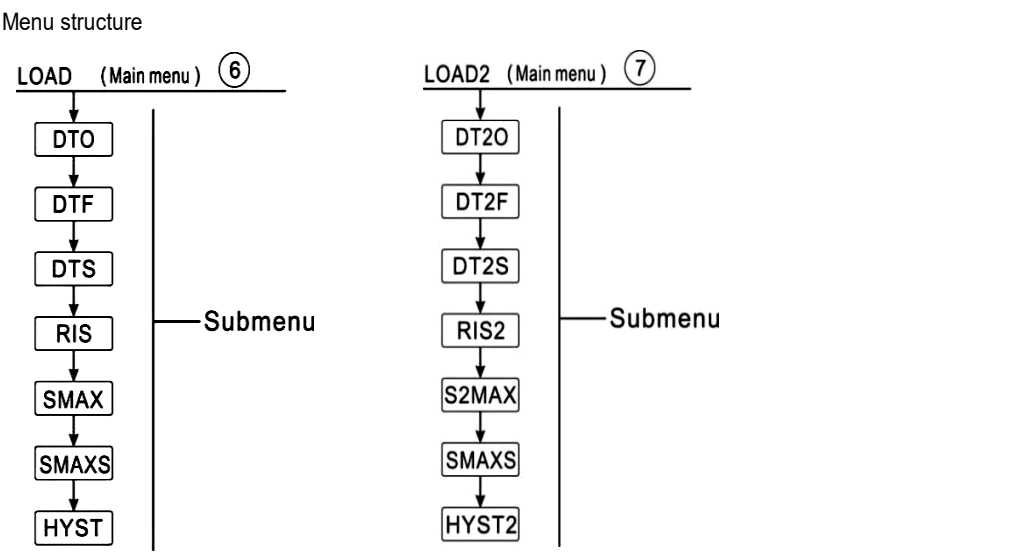

Main menu	Submenu	Default set	Adjust range	Adjust step	Description
LOAD					Tank1 loading set
	DTO	6K	1-50K	0.5K	Switch-on temperature of tank 1
	DTF	4K	0.5-49.5K	0.5K	Switch-off temperature of tank 1
	DTS	10K	1.5-50K	0.5K	Temperature difference for pump speed control of tank1

	RIS	2K	1-20K	1K	Temperature increase rate for pump speed control of tank1
	SMAX	70°C	4-95v	1°C	Maximum temperature of tank 1
	SMAXS	T2	T2.T3		Target sensor select for maximum temperature of tank 1
	HYST	2K	0.1-10K	0.1K	Temperature hysteresis of maximum temperature of tank 1
LOAD2					Tank2 loading set (this menu available in system 3/4/5)
	DT2O	6K	1-50K	0.5K	Switch-on temperature of tank 2
	DT2F	4K	0.5-49.5K	0.5K	Switch-off temperature of tank 2
	DT2S	10K	1.5-50K	0.5K	Temperature difference for pump speed control of tank2
	RIS2	2K	1-20K	1K	Temperature increase rate for pump speed control of tank2
	S2MAX	70°C	4-95°C	1°C	Maximum temperature of tank 2
	SMAXS	T4	T4		Target sensor select for maximum temperature of tank 2
	HYST2	2K	0.1-10K	0.1K	Temperature hysteresis of maximum temperature of tank 2

Function set:

- ▶ Press “SET” key to select main menu “LOAD”
- ▶ Press “SET” button, “DTO 6K” displays on the screen
- ▶ Press “SET” button, “6K” blinks
- ▶ Press “↑”, “↓” key to adjust the switch-on temperature difference of the circuit pump.
- ▶ Press “SET” or “ESC” button, to confirm the setting
- ▶ Press “↑” button, “DTF 4K” display on the screen
- ▶ Press “SET” button, “4K” blinks
- ▶ Press “↑”, “↓” key to adjust the switch-off temperature difference of the circuit pump.

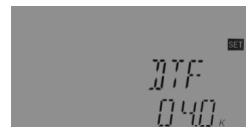

▶ Press “SET” or “ESC” button, to confirm the setting

▶ Press “↑” button, “DTS 10K” display on the screen

▶ Press “SET” button, “10K” blinks

▶ Press “↑”, “↓” key to adjust the standard temperature difference of the circuit pump.



▶ Press “SET” or “ESC” button, to confirm the setting

▶ Press “↑” button, “RIS 2K” display on the screen

▶ Press “SET” button, “2K” blinks

▶ Press “↑”, “↓” key to adjust the temperature difference increase rate of the circuit pump.



▶ Press “SET” or “ESC” button, to confirm the setting

▶ Press “↑” button, “SMAX 70°C” display on the screen

▶ Press “SET” button, “70°C” blinks

▶ Press “↑”, “↓” key to adjust the maximum temperature of tank



▶ Press “SET” or “ESC” button, to confirm the setting

▶ Press “↑” button, “SMAXS T2” display on the screen

▶ Press “SET” button, “T2” blinks

▶ Press “↑”, “↓” key to select sensor used for measuring the maximum temperature of tank.

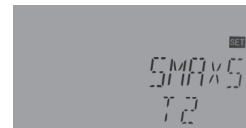

▶ Press “SET” or “ESC” button, to confirm the setting

▶ Press “↑” button, “HYST 2K” display on the screen

▶ Press “SET” button, “2K” blinks

▶ Press “↑”, “↓” key to adjust the hysteresis temperature of the maximum temperature of tank



▶ Press “SET” or “ESC” button, to confirm the setting

Load 2 function is set same like above steps.

6.8./6.9. COL/COL2 Collector function

Function description:

- OCEM (1/2) Collector emergency shutdown

When the collector temperature exceeds the adjusted collector emergency temperature, Then solar pump R1(2) switches off to protect the system components against overheating (collector emergency)

shutdown). If the maximum collector temperature is exceeded OCEM, Warning icon  is displayed and code CEM displays.

 Note: In systems with east- / west collectors, 2 separate menus (COL and COL 2) will be displayed.

 Warning! Risk of injury! Risk of system damage by pressure surge! If water is used as the heat transfer fluid in pressure system, water will boil at 100°C. Do not set the collector limit temperature higher than 95 °C.

- OCCO (1/2) Collector cooling

The collector cooling function is designed to keep the temperature increase of collector within the operating range by the way of heating tank. If the tank temperature reaches 95 °C, this function will switch off the pump due to safety of system.

When the tank temperature exceeds the pre-set maximum tank temperature, then solar pump is switched off. And then collector temperature may rise, if the collector temperature rises to its maximum temperature, the solar pump is switched on again to transfer the energy from collector to tank, pump keeps running until the collector temperature falls below the maximum collector temperature, in this heating process, tank temperature may exceed its maximum temperature, but only up to 95°C (emergency shutdown of the tank)

both icons  are blinks on the screen and code LEM displays, and then pump is stopped.

If the collector cooling is activated,  is displayed and code CMAX displays. This function is only available when the system cooling function (OSYC) and the heat transfer function(OHDP) are deactivated

- OCMI (1/2) Collector minimum temperature

The minimum collector temperature is the lowest switch-on temperature (CMIN) for triggering the solar PumpR1(2), If the collector temperature falls below the minimum temperature,  is displayed and code CMIN displays.

- OCFR (1/2) Collector antifreeze function

When the collector temperature falls below the switch-on temperature CFRO of antifreeze function, this function activates the solar pump to circuit system between collector and tank.

This will protect the fluid against freezing or coagulating. If collector temperature rises and exceeds the switch-off temperature CFRF of anti-freeze function, the solar pump will be switched off.

If collector antifreeze function is activated,  is displayed on the screen.

If collector antifreeze function is running,   are blinks on the screen, and code CFRO displays.



Note: Since this function uses the limited heat energy stored in the tank, the antifreeze function should be used only in regions with few days of temperatures around the freezing point

- OTCO (1/2) Tube collector function

This function is used for improving the switch-on behavior in systems with non-ideal sensor positions (e. g. with some tube collectors).

This function operates within a pre-set time - section. It activates the collector circuit pumpR1(2) intermittently to compensate for the delayed temperature measurement caused by poor sensor position.

If the runtime is set to more than 10s, the pump will run at 100% speed during the first10s, and pump will run at the minimum speed during the remaining runtime.

If the collector sensor is defective, this function will be switched off.

In 2-collector fields systems, the tube collector function is available for each individual collector field.

In 2-collector fields systems, the tube collector function will affect the inactive collector field only. The solar pump of the active collector field will remain switched on until the switch-off conditions are fulfilled.

Menu structure

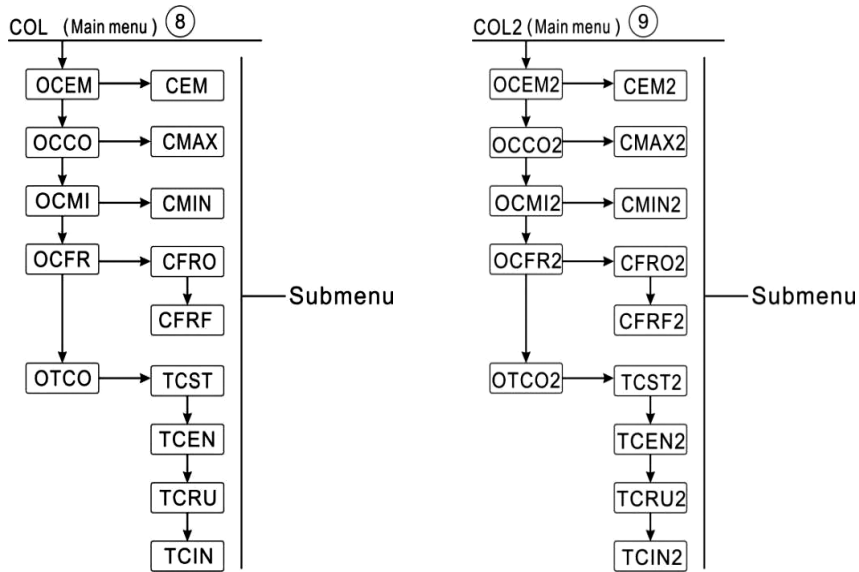

Main menu	Submenu 1	Submenu 2	Default set	Adjust range	Adjust step	Description
COL						Collector 1 function
	OCEM		ON			Emergency shutdown function of collector 1
		CEM	130°C	80-200°C	1°C	Switch-off temperature difference of emergency shutdown of collector 1 (hysteresis 10°C)
	OCCO		OFF			Collector 1 cooling function
		CMAX	110°C	70-160°C	1°C	Collector 1 cooling Temperature (hysteresis 5°C)
	OCMI		OFF			Minimum temperature function of collector 1
		CMIN	10°C	10-90°C	1°C	Minimum temperature of collector 1
	OCFR		OFF			Anti-freeze function of collector 1
		CFRO	4°C	-40-8°C	0.5°C	Switch-on temperature of anti-freeze function of collector 1

		CFRF	5°C	-39-9°C	0.5°C	Switch-off temperature of anti-freeze function of collector 1
	OTCO		OFF			Tube collector function 1
		TCST	07:00	00:00-23:00	1min	Start time of tube collector function 1
		TCEN	19:00	00:00-23:00	1min	Close time of tube collector function 1
		TCRU	30s	30-300s	1s	Run time of tube collector function 1
		TCIN	30min	5-60min	1min	Stop time of tube collector function 1
Main menu	Submenu 1	Submenu 2	Default set	Adjust range	Adjust step	Description
COL 2						Collector 2 function (only available in system 6)
	OCEM2		ON			Emergency shutdown function of collector 2
		CEM2	130°C	80-200°C	1°C	Switch-off temperature difference of emergency shutdown of collector 2 (hysteresis 10°C)
	OCCO2		OFF			Collector 2 cooling function
		CMAx2	110°C	70-160°C	1°C	Collector2 cooling Temperature(hysteresis 5°C)
	OCMI2		OFF			Minimum temperature function of collector 2
		CMIN2	10°C	10-90°C	1°C	Minimum temperature of collector 2
	OCFR2		OFF			Anti-freeze function of collector 2
		CFRO2	4°C	-40-8°C	0.5°C	Switch-on temperature of anti-freeze function of collector 2
		CFRF2	5°C	-39-9°C	0.5°C	Switch-off temperature of anti-freeze function of collector 2
	OTCO2		OFF			Tube collector function 2
		TCST2	07:00	00:00-23:00	1min	Start time of tube collector2function

		TCEN2	19:00	00:00-23:00	1min	Close time of tube collector 2function
		TCRU2	30s	30-300s	1s	Run time of tube collector 2function
		TCIN2	30min	5-60min	1min	Stop time of tube collector2 function

Function setting:

OCEM(Collector emergency shutdown function)

- ▶ Press “SET” key to select main menu “COL”
- ▶ Press “SET” button, “OCEM” displays on the screen
- ▶ Press “SET” button, “OCEM ON” displays on the screen.
- ▶ Press “SET” button, “ON” blinks

If to close the function, then press “↑”, “↓” to switch to “OFF”

- ▶ Press “SET” or “ESC” button, to confirm the setting
- ▶ Press “↑”, “CEM 130°C” displays on the screen
- ▶ Press “SET” button, “130°C” blinks
- ▶ Press “↑”, “↓” key to adjust the switch-off temperature of the collector emergency shutdown function
- ▶ Press “SET” or “ESC” button, to confirm the setting
- ▶ Press “ESC” key to return to the previous menu

OCCO (Collector cooling function) setting

- ▶ Press “↑”, “OCCO” displays on the screen
- ▶ Press “SET” button, “OCCO OFF” displays on the screen
- ▶ Press “SET” button, “OFF” blinks
- ▶ Press “↑”, “↓” key to activate this function, “OCCO ON” displays on the screen
- ▶ Press “↑”, “C MAX 110°C” displays on the screen
- ▶ Press “SET” button, “110°C” blinks
- ▶ Press “↑”, “↓” key to adjust the collector cooling temperature
- ▶ Press “SET” or “ESC” button, to confirm the setting
- ▶ Press “ESC” key to return to the previous menu

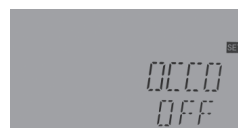
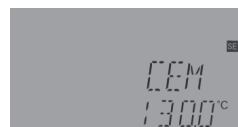

OCMI(Minimum collector temperature) setting

▶ Press “↑”, “OCMI” displays on the screen



▶ Press “SET” button, “OCMI OFF” displays on the screen

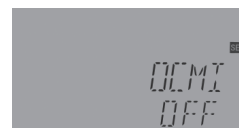

▶ Press “SET” button, “OFF” blinks

▶ Press “↑”, “↓” key to activate this function, “OCMI ON” displays on the screen

▶ Press “↑”, “CMIN 10°C” displays on the screen



▶ Press “SET” button, “10°C” blinks

▶ Press “↑”, “↓” key to adjust the collector minimum temperature

▶ Press “SET” or “ESC” button, to confirm the setting

▶ Press “ESC” key to return to the previous menu



OCFR (Anti-freezing function) setting

▶ Press “↑”, “OCFR” displays on the screen

▶ Press “SET” button, “OCFR OFF” displays on the screen

▶ Press “SET” button, “OFF” blinks

▶ Press “↑”, “↓” key to activate this function, “OCFR ON” displays on the screen

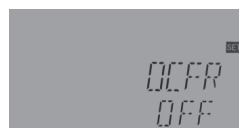

▶ Press “↑”, “CFRO 4°C” displays on the screen

▶ Press “SET” button, “4 °C” blinks

▶ Press “↑”, “↓” key to adjust the switch-on temperature of anti-freezing function

▶ Press “SET” or “ESC” button, to confirm the setting

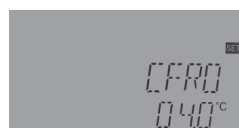

▶ Press “↑”, “↓” key to activate this function, “OCFR ON” displays on the screen

▶ Press “↑”, “CFRF 5°C” displays on the screen

▶ Press “SET” button, “5°C” blinks

▶ Press “↑”, “↓” key to adjust the switch-off temperature of anti-freezing function

▶ Press “SET” or “ESC” button, to confirm the setting

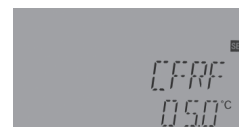

- ▶ Press “ESC” key to return to the previous menu

OTCO (Tube collector function) set

- ▶ Press “↑”, “OTCO” displays on the screen
- ▶ Press “SET” button, “OTCO OFF” displays on the screen
- ▶ Press “SET” button, “OFF” blinks
- ▶ Press “↑”, “↓” key to activate this function, “OTCO ON” displays on the screen
- ▶ Press “↑”, “TCST 07:00” displays on the screen
- ▶ Press “SET” button, hour “07” blinks
- ▶ Press “↑”, “↓” key to adjust time hour of this function
- ▶ Press “SET” button, minute “00” blinks
- ▶ Press “↑”, “↓” key to adjust time minute of this function
- ▶ Press “SET” or “ESC” button, to confirm the setting
- ▶ Press “↑”, “TCEN 19:00” displays on the screen
- ▶ Press “SET” button, hour “19” blinks
- ▶ Press “↑”, “↓” key to adjust time hour of this function
- ▶ Press “SET” button, minute “00” blinks
- ▶ Press “↑”, “↓” key to adjust time minute of this function
- ▶ Press “SET” or “ESC” button, to confirm the setting
- ▶ Press “↑”, “TCRU 30” displays on the screen
- ▶ Press “SET” button, runtime “30” blinks
- ▶ Press “↑”, “↓” key to adjust the runtime (unit: second)
- ▶ Press “SET” or “ESC” button, to confirm the setting
- ▶ Press “↑”, “TCIN 30Min” displays on the screen
- ▶ Press “SET” button, runtime “30” blinks
- ▶ Press “↑”, “↓” key to adjust the stop time (unit: second)
- ▶ Press “SET” or “ESC” button, to confirm the setting
- ▶ Press “ESC” key to return to the previous menu

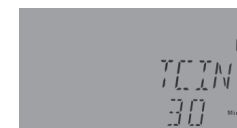
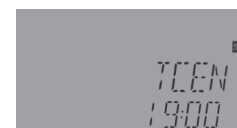
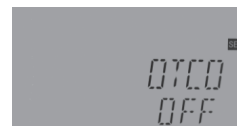

For COL2 function, its setup steps are same as above description.

6.10.PUMP Pump control mode

Function description:

With this function, the control mode of pump's relay can be adjusted. The following types can be selected:

- Control mode for standard pump without speed control:
 - OnOF: Pump on / pump off
- Control mode for standard pump with speed control:
 - PULS: Burst control via semiconductor relay
- Control mode for high-efficiency pump (HE pump)
 - PSOL: PWM signal logic of solar pump

PWM signal logic (solar):

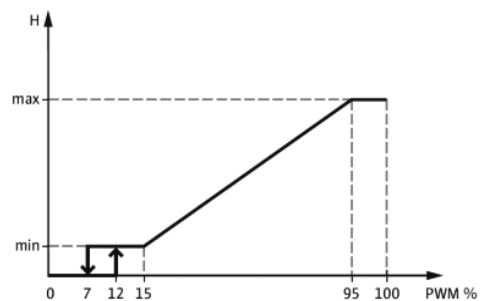

- PHEA: PWM signal logic of heating pump

PWM signal logic (heating):

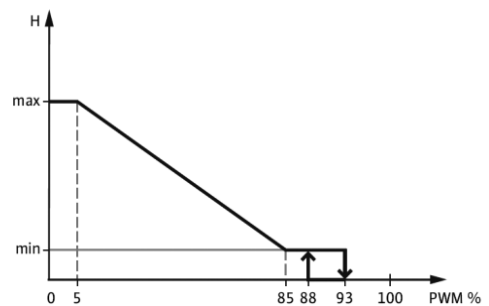

- 0-10: PWM 0 - 10 V signal logic of speed control

PWM(0-10V) signal logic

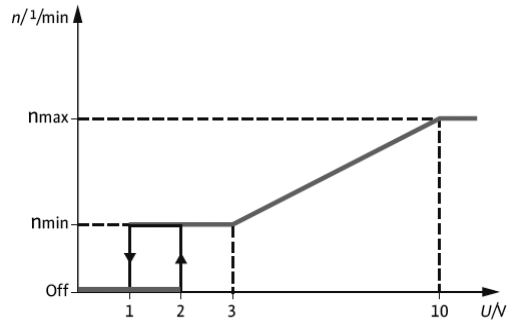

Note:

- 1) More information about connection of high efficiency pump see paragraph 3.3
- 2) Minimum pump speed: Under the adjustment menu MIN1, MIN2, MIN3, a relative minimum speed for the connected pump can be allocated to the outputs R1, R2, R3.
- 3) Maximum pump speed: Under the adjustment menu MAX1, MAX2, MAX3, a relative maximum speed for the connected pump can be allocated to the outputs R1, R2, R3.
- 4) When the devices which are not speed-controlled are used (e. g. valves), the pump speed value of the corresponding relay must be set to 100 % or the control type must be set to ONOF to deactivate pump speed control
- 5) Allocation for PWM output relay: a relay can be allocated to a PWM output; PWM1 for R1, PWM2 for R2, PWM3 for R3

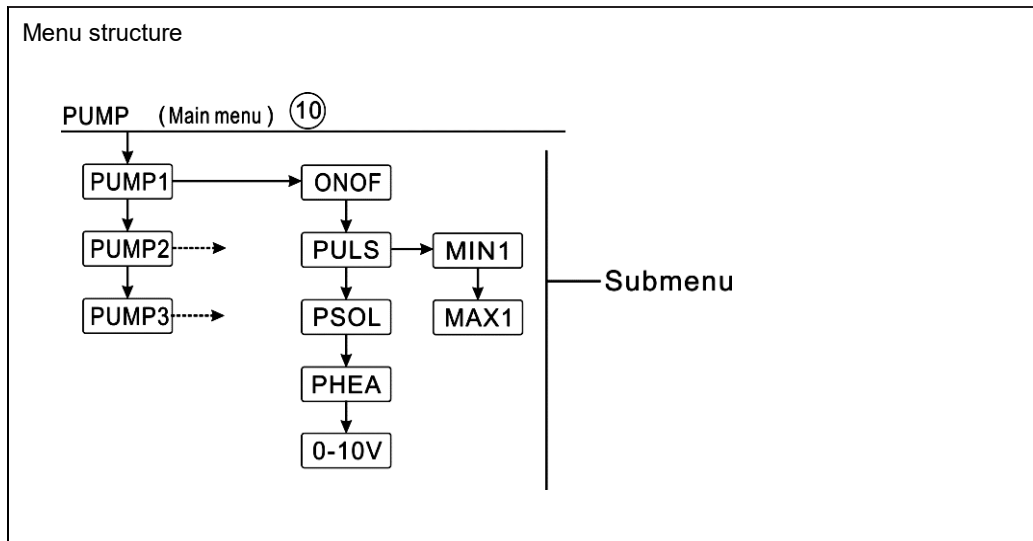

Main menu	Submenu 1	Submenu 2	Submenu 3	Default set	Adjust range	Adjust step	Description
PUMP							Pump control mode
	PUMP1(2, 3)						Pump R1(R2, R3) selection
		ONOF		ON	ON/OFF		ON/OFF control of standard pump, (without pump speed adjust)
		PULS		OFF	ON/OFF		Pulse control of standard pump (through semiconductor relay)
			MIN1	50%	20-95%	5%	
			MAX1	100%	25-100%	5%	
		PSOL		OFF	ON/OFF		PWM control solar pump
			MIN1	50%	20-95%	5%	
			MAX1	100%	25-100%	5%	
		PHEA		OFF	ON/OFF		PWM control heating pump
			MIN1	50%	20-95%	5%	
			MAX1	100%	25-100%	5%	
		0-10		OFF	ON/OFF		0-10V signal control pump speed
			MIN1	50%	20-95%	5%	
			MAX1	100%	25-100%	5%	

Function set:

- ▶ Press "SET" key to select main menu "PUMP"
- ▶ Press "SET" button, "PUMP1" displays on the screen (pump R1 control mode selection)
- ▶ Press "SET" button, "ONOF ON" displays on the screen
- ▶ Press "↑", "↓" button, to select pump control mode "ONOF, PLUS, PSOL, PHEA, 0-10V"
- ▶ Press After select pump type, press "SET" to access the pump type window



- ▶ Press “SET” button, “OFF” blinks
- ▶ Press “↑”, “↓” key to activate the selected pump type
- ▶ Press “SET” or “ESC” button, to confirm the setting
- ▶ Press “↑”, “MIN1 50” displays on the screen, to enter the minimum pump speed setup (PLUS、PSOL、PHEA、0-10V control mode has pump speed, example with PLUS ON)
- ▶ Press “SET” button, “50” blinks
- ▶ Press “↑”, “↓” key to adjust minimum pump speed
- ▶ Press “SET” or “ESC” button, to confirm the setting
- ▶ Press “↑”, “MAX1 100 ” displays on the screen,
- ▶ Press “↑”, “↓” key to adjust maximum pump speed
- ▶ Press “SET” or “ESC” button, to confirm the setting
- ▶ Press “ESC” key to return to the previous menu
- ▶ Press “↑”to access the PUMP2 set (pump R2 control mode selection)



Note:

- 1) PUMP2, PUMP3 setup step is same as PUMP1
 - 2) Only one mode can be selected from five modes ONOF、PLUS、PSOL、PHEA、0-10V
- Example: if you select “PLUS ON” type, then the others are closed automatically.

6.11.LLOGITank priority logic

Function description:

- Priority logic

Priority logic is designed for systems with 2-tanks or systems with tank loading in layers; it determines how the heat is divided between the tanks. Several different priority logic types can be selected:

- 1) Tanks loading in sequence (1 and 2)
- 2) Successive loading (Su 1 and Su 2)
- 3) Parallel loading (0)

- Tanks heated in sequence (1 and 2)

If the priority tank is not loaded because its switch-on condition is not reached, then the subordinate tank is checked whether its switch-on condition is reached, if yes, then it is loaded during the circulation runtime (tRUN). After runtime, heating process stops, then break time timer tLB starts to ensure collector to receive more solar energy, during the break time, if the priority tank switch-on condition is still not reached, then the subordinate tank will be loaded again for the circulation runtime.

As soon as the priority tank meets its switch-on condition, controller triggers to heat it immediately, if the priority tank's switch-on condition is still not reached, controller heats the subordinate tank continuously. If the priority tank reaches to its preset temperature, and then tank heated sequence function is stopped.

In systems with 2 tanks or tank loading in layers, all tanks or zones will be heated to its preset temperature firstly (base the priority and sequence control logic). Only when all tanks or zones have exceeded its preset temperature, they just can be heated to their maximum temperature continuously, and it is also heated base the priority and sequence control logic.

- Successive loading (Su 1 and Su 2)

Successive loading means that the priority tank will be heated to its maximum temperature. After the priority tank reaches its maximum temperature, then the second tank will just be heated. If the temperature of the priority tank falls below its pre-set temperature, then the second tank will no longer be heated, regardless of whether the switch-on condition of the priority tank or the second tank is met. If both tanks are heated to their preset temperature, the same process will occur until the tank reaches its maximum temperature

- Parallel loading (0)

In systems with 2 pumps, if parallel loading control logic is selected, 2 tanks will be heated parallel. In system with 3 - ways valve, tank which temperature is lower will be heated in advance until its temperature is 5K higher than another tank, and then the second tank just can be heated. Two tanks are alternately heated with a 5K temperature difference.

- OSTs Tank set option (only available at LLOGI/PRIO 1or 2 mode)

If the priority tank reaches its pre-set temperature, then the subordinate tank will be heated until to its

set temperature. After this, priority tank can be loaded to its maximum temperature, and then system is switched to load the subordinate tank. This function is suitable for 2 tanks' system.

- OSE Spread loading function (only available at LLOGI/PRI01,2,Su1 or Su2mode)

In system5, spread loading function will be activated. When the spread temperature difference DTSE between collector and priority tank is reached, the second tank will be loaded in parallel unless it is blocked. If the spread temperature difference falls 2K below DTSE temperature, the pump will be switched off. The collector temperature should be higher than the tank temperature.

- PDELR Pump delay running

Considering the trigger-on time of the electromagnetic valve this function delays the start of the pump, if this function is activated, corresponding valve relay is triggered firstly, and pump is delayed starting in 20 seconds.

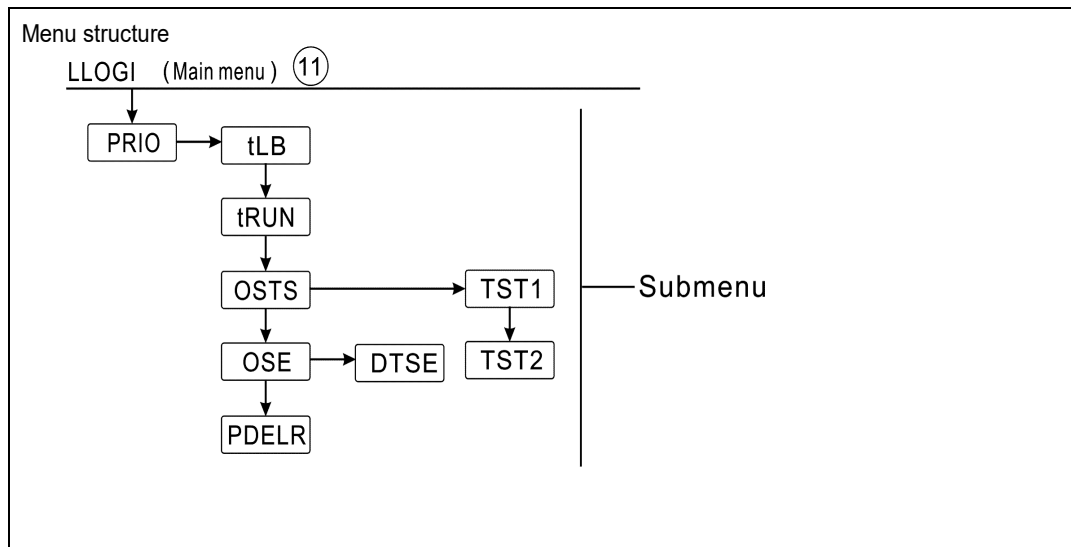

Main menu	Submenu 1	Submenu 2	Submenu 3	Default set	Adjust range	Adjust step	Description
LLOGI							Tank heating logic (this menu only available in system3/4/5)
	PRI0			2	1/2/SU1/SU2/0		Tank priority logic
		tLB		2min	1-30min	1min	Heating runtime

		tRUN		15min	1-30min	1min	Heating rest time
		OSTS		OFF	ON/OFF		Tank temperature set option
			TST1	45°C	4-85°C	1°C	Temperature set of tank 1
			TST2	45°C	4-85°C	1°C	Temperature set of tank 2
		OSE		OFF	ON/OFF		Spread loading function
			DTSE	40K	20-90K	1K	Spread temperature difference
		PDELR		OFF	ON/OFF		Pump delay running function

Function set:

- ▶ Press “SET” key to select main menu “LLOGI”
- ▶ Press “SET” button, “PRIO 2” displays on the screen (here take PRIO2 as example)
- ▶ Press “SET” button, “2” blinks on the screen
- ▶ Press “↑”, “↓” button, to select tank priority logic
- ▶ Press “SET” or “ESC” button, to confirm the setting

- ▶ Press “↑”, “tLB 2min” displays on the screen
- ▶ Press “SET” button, “2min” blinks on the screen
- ▶ Press “↑”, “↓” button, to adjust the runtime of heating
- ▶ Press “SET” or “ESC” button, to confirm the setting
- ▶ Press “↑”, “tRUN 15min” displays on the screen
- ▶ Press “SET” button, “15min” blinks on the screen
- ▶ Press “↑”, “↓” button, to adjust the break time of heating
- ▶ Press “SET” or “ESC” button, to confirm the setting

- ▶ Press “↑”, “OSTSOFF” displays on the screen
- ▶ Press “SET” button, “OFF” blinks on the screen

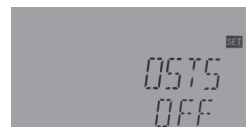
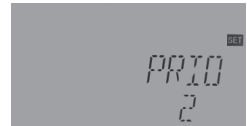

▶ Press “↑”, “↓”button, to activate tank temperature set function

▶ Press “SET” or “ESC” button, to confirm the setting

▶ Press “↑”, “TST1 45°C” displays on the screen

▶ Press “SET” button, “45°C” blinks on the screen

▶ Press “↑”, “↓”button, to adjust the temperature of tank 1

▶ Press “SET” or “ESC” button, to confirm the setting

▶ Press “↑”, “TST2 45°C” displays on the screen

▶ Press “SET” button, “45°C” blinks on the screen

▶ Press “↑”, “↓”button, to adjust the temperature of tank 2

▶ Press “SET” or “ESC” button, to confirm the setting



▶ Press “↑”, “OSE OFF” displays on the screen

▶ Press “SET” button, “OFF” blinks on the screen

▶ Press “↑”, “↓”button, to activate spread loading function

▶ Press “SET” or “ESC” button, to confirm the setting

▶ Press “↑”, “DTSE 40K” displays on the screen

▶ Press “SET” button, “40K” blinks on the screen

▶ Press “↑”, “↓”button, to adjust the spread temperature difference

▶ Press “SET” or “ESC” button, to confirm the setting

▶ Press “↑”, “PDEL R OFF” displays on the screen

▶ Press “SET” button, “OFF” blinks on the screen

▶ Press “↑”, “↓”button, to activate the pump delay running function

▶ Press “SET” or “ESC” button, to confirm the setting

▶ Press “ESC” button, to return to the previous menu

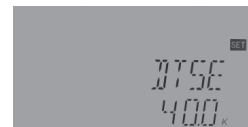
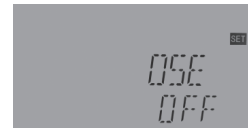

6.12.COOLCooling function

Function description:

Different cooling functions for different devices can be activated: system cooling, tank cooling and external radiator heat transfer.

- OSYC System cooling

The system cooling function is designed to keep the solar system operation for a longer time. The

function overrides the maximum tank temperature to transfer the energy from collector field to the tank. If the tank temperature is higher than its maximum tank temperature already and the switch-on temperature difference of this function DTCO is reached, then the solar pump remains running. Solar loading is continued until either the temperature difference falls below the switch-off temperature DTCF or the collector emergency temperature OCEM reaches.

If the system cooling function is running, then icon  displays, and icon  blinks on the screen, code OSYC displays on the screen.



Note: This function will only be available when the collector cooling function, external radiator heat transfer functions are deactivated.

- OSTC Tank cooling

When the tank cooling function is activated, this function is designed to cool down the tank during the night and provide possibility for solar loading on the following day. If the maximum tank temperature SMAX is exceeded, the collector temperature falls below the tank temperature, and it is below the switch on temperature difference DTCO of this cooling function, then system will be activated to cool down the tank by releasing the energy through the collector in night.

If the tank cooling function is running, icon  displays, and icon  blinks on the screen, code OSTC displays.



Note: if tank temperature reaches to 95 °C, all cooling functions will be locked. Hysteresis switch on temperature difference is 5K.

- OHDP external radiator heat transfer

Under strong solar irradiation, external radiator heat transfer function is designed to release the excess thermal energy which generated by solar system through an external heat exchanger (e. g. fan coil), aim is to keep the temperature of collector or tank within its operation range. For this function, an extra output RX is needed. (due to system different, the output relay for circuit pump RX is different also, detailed allocation see diagram showed in 4.2 system description.

External radiator heat transfer function can either control an additional pump or valve (OTPUM

ON = pump logic, OTPUM OFF = valve logic).

- Heat transfer by pump logic:

When tank temperature reaches its maximum temperature, If the collector temperature reaches the switch-on temperature(OTST) of heat transfer function, the heat transfer pump(RX) is triggered. if the collector temperature falls 5 K below heat transfer temperature(OTST),the heat transfer pump(RX) is off.

- Heat transfer by valve logic:

When tank temperature reaches its maximum temperature, If the collector temperature reaches the switch-on temperature(OTST), the heat transfer valve(RX) and circuit pump(R1) on. if the collector temperature falls 5 K below heat transfer temperature(OTST),the heat transfer valve(RX) and circuit pump(R1) off.

Below is the example of this application for reference.

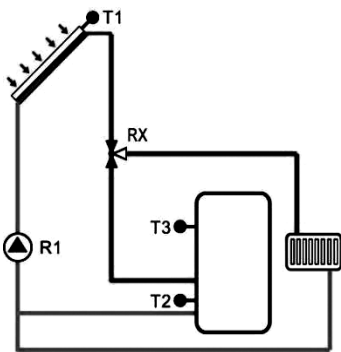

Heat transfer by collector valve logic

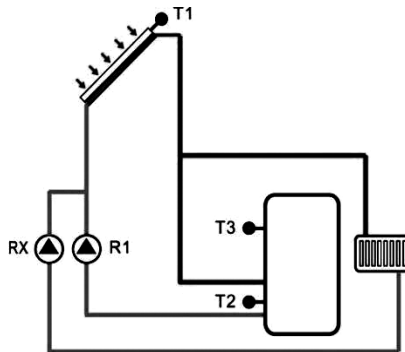

Heat transfer by collector pump logic

i Note:

- 1) The collector over-temperature value OTST is blocked 10K lower against the collector emergency temperature CEM.
- 2) This function will only be available when the collector cooling function "OCCO" and the system cooling function "OSYC" are deactivated.
- 3) According to the selected system, several auxiliary functions are allocated with a same relay output

e.g R2, at this case, then only one of the auxiliary functions can be activated, the other functions will be deactivated automatically, its function displays “NONE”.

4) According the different selected system, the function will be assigned to different output ports.

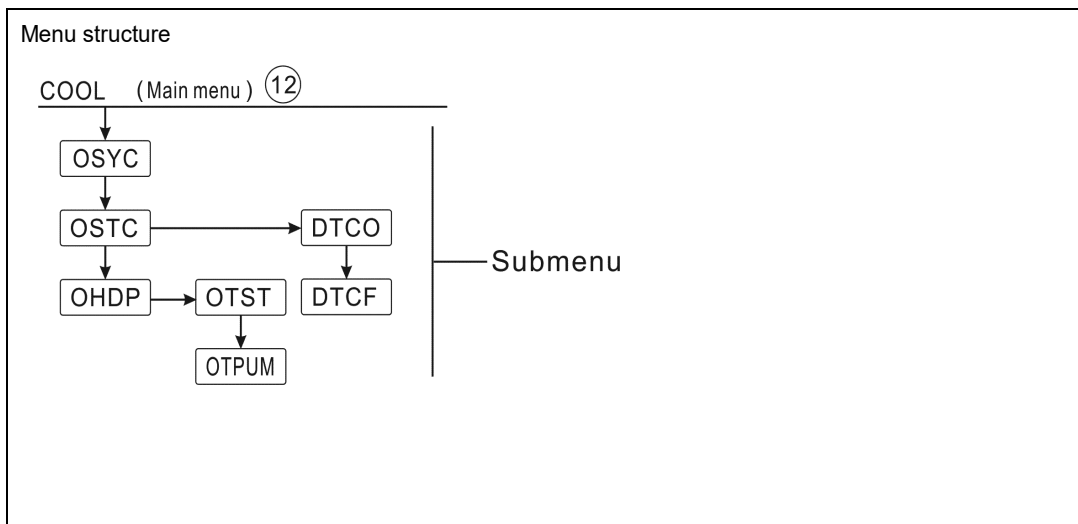

Main menu	Submenu 1	Submenu 2	Default set	Adjust range	Adjust step	Description
COOL						Cooling function
	OSYC		OFF	ON/OFF		System cooling
	OSTC		OFF	ON/OFF		Tank cooling
		DTCO	20K	1-30K	0.5K	Switch-on temperature difference of cooling
		DTCF	15K	0.5-29.5K	0.5K	Switch-off temperature difference of cooling
	OHDP		OFF	ON/OFF		Heat transfer – by extra heat exchanger (only available when there is free relay)
		OTST	80°C	20-160°C	1°C	Temperature set of heat transfer (Hysteresis 5°C)
		OTPM	ON	OTPUM ON=pump logic		Pump and valve logic selection

				OTPUM OFF=valve logic		
--	--	--	--	--------------------------	--	--

Function set:

OSYC System cooling function set

- ▶ Press "SET" key to select main menu "COOL"
- ▶ Press "SET" button, "OSYC OFF" displays on the screen
- ▶ Press "SET" button, "OFF" blinks on the screen
- ▶ Press "↑", "↓" button, to activate this cooling function, "OSYC ON" displays on the screen
- ▶ Press "SET" or "ESC" button, to confirm the setting

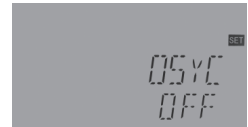

OSTC Tank cooling function set

- ▶ Press "↑", "OSTC" displays on the screen
- ▶ Press "SET" button, "OSTC OFF" displays on the screen
- ▶ Press "SET" button, "OFF" blinks on the screen
- ▶ Press "↑", "↓" button, to activate this cooling function, "OSTC ON" displays on the screen
- ▶ Press "SET" or "ESC" button, to confirm the setting
- ▶ Press "↑", "DTCO 20K" displays on the screen
- ▶ Press "SET" button, "20K" blinks on the screen
- ▶ Press "↑", "↓" button, to adjust the switch-on temperature of cooling function,
- ▶ Press "SET" or "ESC" button, to confirm the setting
- ▶ Press "↑", "DTCF 15K" displays on the screen
- ▶ Press "SET" button, "15K" blinks on the screen
- ▶ Press "↑", "↓" button, to adjust the switch-off temperature of cooling function,
- ▶ Press "SET" or "ESC" button, to confirm the setting
- ▶ Press "ESC" button, to return to the previous menu

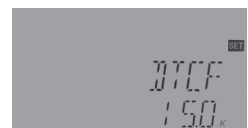
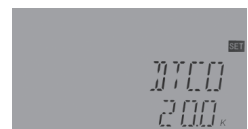
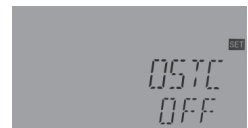

OHDP Heat transfer function set

- ▶ Press "↑", "OHDP" displays on the screen

- ▶ Press “SET” button, “OHDP OFF” displays on the screen
- ▶ Press “SET” button, “OFF” blinks on the screen
- ▶ Press “↑”, “↓”button, to activate this cooling function, “OHDP ON” displays on the screen

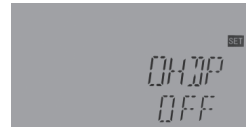

- ▶ Press “SET” or “ESC” button, to confirm the setting
- ▶ Press “↑”, “OTST 80°C” displays on the screen
- ▶ Press “SET” button, “80°C” blinks on the screen
- ▶ Press “↑”, “↓”button, to adjust the switch-on temperature of heat transfer function,



- ▶ Press “SET” or “ESC” button, to confirm the setting
- ▶ Press “↑”, “OTPUM ON” displays on the screen
- ▶ Press “SET” button, “ON” blinks on the screen
- ▶ Press “↑”, “↓”button, to adjust the pump or valve logic of heat transfer function,
- ▶ Press “SET” or “ESC” button, to confirm the setting
- ▶ Press “ESC” button, to return to the previous menu



6.13. HEATX Energy exchange between tanks

Function description:

The relay is energized when all switch-on conditions below listed are met:

- 1) The temperature difference between the sensor of heat source tank and heated tank has exceeded the switch-on temperature difference DTHXO.
- 2) The temperature at the heat source sensor has exceeded its minimum temperature MNHXO
- 3) The temperature at the heated tank sensor is below its maximum temperature MXHXO.
- 4) When the set temperature difference is exceeded, pump speed control starts. For every decrease or increase by the rise value, the pump speed will be adjusted by 10%.



Note: this function is only available in system 2, The heat exchange function is designed to transfer heat from a heat source tank to another heated tank.

Menu structure

HEATX (Main menu) ⑬

DTHXO

DTHXF

DTHXS

RISHX

MXHXO

MNHXO

Submenu

Main menu	Submenu	Default set	Adjust range	Adjust step	Description
HEATX		0FF	ON/OFF		Heat transfer between tanks (only available in system 2)
	DTHXO	6K	1-50K	0.5K	Switch-on temperature difference of heat transfer between tanks
	DTHXF	4K	0.5-49.5K	0.5K	Switch-off temperature difference of heat transfer between tanks
	DTHXS	10K	1.5-50K	0.5K	Pump speed control - Temperature difference of two tanks
	RISHX	2K	1-20K	1K	Pump speed control – Temperature increase range of two tanks
	MXHXO	70°C	0.5-95°C	0.5°C	Maximum temperature of heated tank(Hysteresis 2°C)
	MNHXO	60°C	0.5-89.5°C	0.5°C	Minimum temperature of heat source tank (Hysteresis 2°C)

Function set:

- ▶ Press “SET” key to select main menu “HEATX”
- ▶ Press “SET” button, “DTHXO 6K” displays on the screen
- ▶ Press “SET” button, “6K” blinks on the screen
- ▶ Press “↑”, “↓”button, to adjust the switch-on temperature difference of heat transfer between 2 tanks
- ▶ Press “SET” or “ESC” button, to confirm the setting

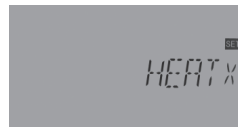

- ▶ Press “↑”, “DTHXF 4K” displays on the screen
- ▶ Press “SET” button, “4K” blinks on the screen
- ▶ Press “↑”, “↓”button, to adjust the switch-off temperature difference of heat transfer between 2 tanks

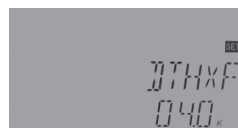

- ▶ Press “SET” or “ESC” button, to confirm the setting
- ▶ Press “↑”, “DTHXS 10K” displays on the screen
- ▶ Press “SET” button, “10K” blinks on the screen
- ▶ Press “↑”, “↓”button, to adjust the standard temperature difference of circuit pump

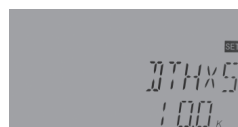

- ▶ Press “SET” or “ESC” button, to confirm the setting

- ▶ Press “↑”, “RISHX 2K” displays on the screen
- ▶ Press “SET” button, “2K” blinks on the screen
- ▶ Press “↑”, “↓”button, to adjust the temperature increase range
- ▶ Press “SET” or “ESC” button, to confirm the setting



- ▶ Press “↑”, “MXHXO 70 °C” displays on the screen
- ▶ Press “SET” button, “70 °C” blinks on the screen
- ▶ Press “↑”, “↓”button, to adjust the maximum temperature of heated tank
- ▶ Press “SET” or “ESC” button, to confirm the setting

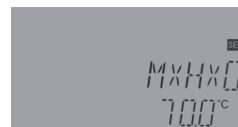

- ▶ Press “↑”, “MINHXO 60°C” displays on the screen
- ▶ Press “SET” button, “60°C” blinks on the screen
- ▶ Press “↑”, “↓”button, to adjust the minimum temperature of heat source tank
- ▶ Press “SET” or “ESC” button, to confirm the setting



- ▶ Press “ESC”, to return the previous menu

6.14.RPH Heating return pipe preheat

Function description:

The relay is energized when both switch-on conditions are met:

- 1) The temperature difference between the sensor of heat source tank and sensor of the heating circuit return has exceeded the switch-on temperature difference DTRPO.
- 2) The temperature at the heating circuit return has exceeded its minimum temperature MNRPH, the switch-on hysteresis is -5 K.



Note: this function is available in system 7. The heating return pipe preheat function is designed to transfer energy from a heat source to heating circuit return.

Menu structure					
<div style="text-align: center;"> <p>RPH (Main menu) ⑭</p> <pre> graph TD RPH --> TANK TANK --> DTRPO DTRPO --> DTRPF DTRPF --> MNRPH </pre> <p>Submenu</p> </div>					
Main menu	Submenu	Default set	Adjust range	Adjust step	Description
RPH		0FF	ON/OFF		Heating return pipe heat function
	TANK	T3	T2,T3		Tank sensor selection
	DTRPO	6K	1-50K	0.5K	Switch-on temperature difference
	DTRPF	4K	0.5-49.5K	0.5K	Switch-off temperature difference
	MNRPH	30°C	1.5-89.5°C	0.5°C	Minimum temperature of heating return pipe (hysteresis 5°C)

Function set:

- ▶ Press “SET” key to select main menu “RPH”
- ▶ Press “SET” button, “TANK T3” displays on the screen
- ▶ Press “SET” button, “T3” blinks on the screen
- ▶ Press “↑”, “↓”button, to select the sensor for heating return pipe heat



function

- ▶ Press “SET” or “ESC” button, to confirm the setting
- ▶ Press “↑”, “DTRPO 6K” displays on the screen
- ▶ Press “SET” button, “6K” blinks on the screen
- ▶ Press “↑”, “↓”button, to adjust the switch-on temperature
- ▶ Press “SET” or “ESC” button, to confirm the setting
- ▶ Press “↑”, “DTRPF 4K” displays on the screen
- ▶ Press “SET” button, “4K” blinks on the screen
- ▶ Press “↑”, “↓”button, to adjust the switch-off temperature
- ▶ Press “SET” or “ESC” button, to confirm the setting
- ▶ Press “↑”, “MNRPH 30°C” displays on the screen
- ▶ Press “SET” button, “30°C” blinks on the screen
- ▶ Press “↑”, “↓”button, to adjust the minimum temperature of heating

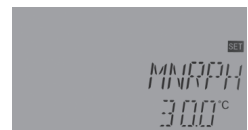

return pipe

- ▶ Press “SET” or “ESC” button, to confirm the setting

6.15.SFB Solid fuel boiler function

Function description:

The solid fuel boiler function is designed to transfer heat from a solid fuel boiler to a tank, for this function, it needs a sensor input and output relay.

The relay is energized when all switch-on conditions are met:

- 1) The temperature difference between the sensors of solid fuel boiler and heated tank exceeds the switch-on temperature difference.
- 2) The temperature at the solid fuel boiler sensor exceeds its minimum temperature (MINSFO)
- 3) The temperature at the heated tank is lower than its maximum temperature (MXSFS)
- 4) When the preset temperature difference is exceeded, pump speed control starts. For every increase or decrease by the rise value, the pump speed will be adjusted by 10 % in sequence. The switch-on hysteresis is -5 K.



Note:

- 1) In system 2/4/5, boiler backup heating (BOIL) and solid fuel boiler (SFD) function, only one can be enabled.

- 2) In system 7, it is not deigned with this function.
- 3) According the different selected system, this function will be assigned to the different object sensors and output ports
- 4) sensor on the upper part of the heated tank is the priority sensor, if on the upper part no sensor is installed or sensor is damaged, then controller will take the signal from bottom sensor automatically.

Menu structure					
<pre> graph TD SFB["SFB (Main menu) 15"] --> ONOFF["ON/OFF"] ONOFF --> DTSFO["DTSFO"] DTSFO --> DTSFF["DTSFF"] DTSFF --> DTSFS["DTSFS"] DTSFS --> RISSF["RISSF"] RISSF --> MXSFS["MXSFS"] MXSFS --> MNSFO["MNSFO"] </pre>					
Main menu	Submenu	Default set	Adjust range	Adjust step	Description
SFB		OFF	ON/OFF		Solid fuel boiler function
	DTSFO	6K	1-50K	0.5K	Switch-on temperature difference
	DTSFF	4K	0.5-49.5K	0.5K	Switch-off temperature difference
	DTSFS	10K	1.5-50K	0.5K	Pump speed control – temperature difference set
	RISSF	2K	1-20K	1K	Pump speed control – temperature increase rate
	MXSFS	60°C	0.5-95°C	0.5°C	Maximum temperature of heated tank (hysteresis 2°C)
	MNSFO	60°C	0.5-89.5°C	0.5v	Minimum temperature of solid fuel boiler (hysteresis 2°C)

Function set:

- ▶ Press “SET” key to select main menu “SFB”
- ▶ Press “SET” button, “SFB OFF” displays on the screen
- ▶ Press “SET” button, “OFF” blinks on the screen
- ▶ Press “↑”, “↓” button, to activate this function, “SFB ON” displays on the screen

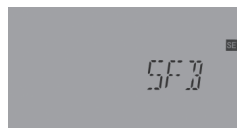

- ▶ Press “SET” or “ESC” button, to confirm the setting
- ▶ Press “↑” button, “DTSFO 6K” displays on the screen
- ▶ Press “SET” button, “6K” blinks on the screen
- ▶ Press “↑”, “↓” button, to adjust the switch-on temperature difference
- ▶ Press “SET” or “ESC” button, to confirm the setting

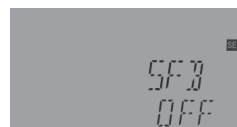

- ▶ Press “↑” button, “DTSFF 4K” displays on the screen
- ▶ Press “SET” button, “4K” blinks on the screen
- ▶ Press “↑”, “↓” button, to adjust the switch-off temperature difference
- ▶ Press “SET” or “ESC” button, to confirm the setting

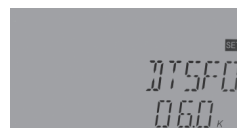

- ▶ Press “↑” button, “DTSFF 4K” displays on the screen
- ▶ Press “SET” button, “4K” blinks on the screen
- ▶ Press “↑”, “↓” button, to adjust the switch-off temperature difference
- ▶ Press “SET” or “ESC” button, to confirm the setting



- ▶ Press “↑” button, “DTSFS 10K” displays on the screen
- ▶ Press “SET” button, “10K” blinks on the screen
- ▶ Press “↑”, “↓” button, to adjust the standard temperature difference for pump circuit
- ▶ Press “SET” or “ESC” button, to confirm the setting

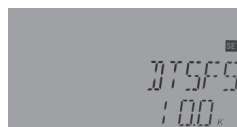

- ▶ Press “↑” button, “RISSF 2K” displays on the screen
- ▶ Press “SET” button, “2K” blinks on the screen
- ▶ Press “↑”, “↓” button, to adjust temperature increase rate
- ▶ Press “SET” or “ESC” button, to confirm the setting
- ▶ Press “↑” button, “MXSFS 60°C” displays on the screen
- ▶ Press “SET” button, “60°C” blinks on the screen



- ▶ Press “↑”, “↓” button, to adjust the switch-off temperature (maximum) of heated tank
- ▶ Press “SET” or “ESC” button, to confirm the setting
- ▶ Press “↑” button, “MNSFO 60°C” displays on the screen
- ▶ Press “SET” button, “60 °C” blinks on the screen
- ▶ Press “↑”, “↓” button, to adjust the minimum switch-on temperature of solid fuel boiler



- ▶ Press “SET” or “ESC” button, to confirm the setting
- ▶ Press “ESC” button, to return to the previous menu

6.16.AH Thermostat function

Function description:





Due to different system , if all auxiliary functions need R3 output relay port (refer system diagram in 4.2) , then only one function can be enabled, and other functions is closed automatically, and display “NONE”. If it is needed to trigger the function, then deactivated other functions.

Due to different system selected , this function will be assigned to the different object sensor and output relay port

The thermostat function is independent from the solar operation system, it can e. g. be used for using surplus energy or for back-up heating. (Every day 3 heating time - sections can be set)



Note:

1. AH O < AH F: Thermostat function used for back-up heating
2. AH O > AH F: Thermostat function used for releasing surplus energy from tank.
3. Icon  displays on the screen, it means thermostat function for back-up heating is activated.  flashes, it indicates this function is running.
4. Icon  displays on the screen, it means thermostat function for heating release is activated, icon  flashes, it means that function is running.

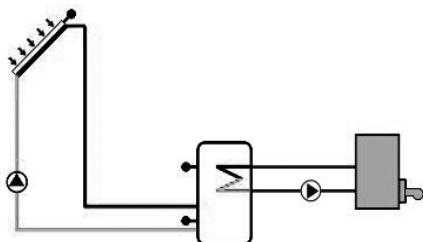

Back-up heating

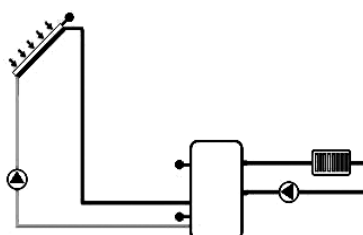

Release heating

Menu structure

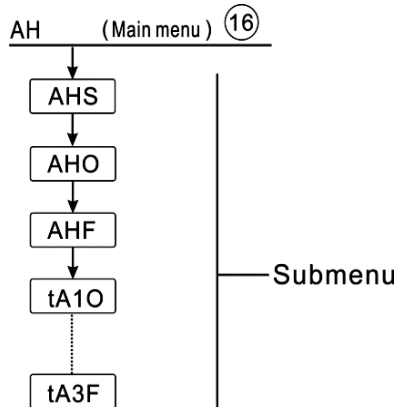

Main menu	Submenu 1	Submenu 2	Default set	Adjust range	Adjust step	Description
AH			OFF	ON/OFF		Thermostat function
	AHS		T3	T2-T3 可选		Target sensor for thermostat function
		AHO	40°C	0.0-95°C	0.5°C	Switch-on temperature
		AHF	45°C	0.0-94.5°C	0.5°C	Switch-off temperature
		t A1O	00:00	00:00-23:59		Start time of the first time-section
		t A1F	00:00	00:00-23:59		Close time of the first time- section
		t A2O	00:00	00:00-23:59		Start time of the second time-section
		t A2F	00:00	00:00-23:59		Close time of the second first timesection
		t A3O	00:00	00:00-23:59		Start time of the third time-section
		t A3F	00:00	00:00-23:59		Close time of the third time- section

Function set:

▶ Press "SET" key to select sub-menu "AH", "AH" displays on the screen

▶ Press "SET" button, "AH OFF" displays on the screen

▶ Press "SET" button, "OFF" blinks on the screen

▶ Press "↑", "↓" button, to activate this function "AH ON" displays on the screen

▶ Press "SET" or "ESC" button, to confirm the setting

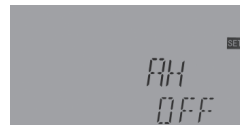

▶ Press "↑" button, "AHS T3" displays on the screen

▶ Press "SET" button, "T3" blinks on the screen

▶ Press "↑", "↓" button, to select the desired sensor for thermostat function

▶ Press "SET" or "ESC" button, to confirm the setting

▶ Press "↑" button, "AHO 40°C" displays on the screen

▶ Press "SET" button, "40°C" blinks on the screen

▶ Press "↑", "↓" button, to adjust the switch-on temperature of thermostat function

▶ Press "SET" or "ESC" button, to confirm the setting

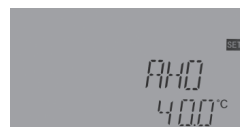

▶ Press "↑" button, "AHF 45°C" displays on the screen

▶ Press "SET" button, "45°C" blinks on the screen

▶ Press "↑", "↓" button, to adjust the switch-off temperature of thermostat function

▶ Press "SET" or "ESC" button, to confirm the setting

▶ Press "↑" button, "tA1O 00:00" displays on the screen

▶ Press "SET" button, hour "00" blinks on the screen

▶ Press "↑", "↓" button, to adjust hour of the start time of the first time - section of thermostat function

▶ Press "SET" button, minute "00" blinks on the screen

▶ Press "↑", "↓" button, to adjust minute of the start time of the first time - section of thermostat function

▶ Press "SET" or "ESC" button, to confirm the setting

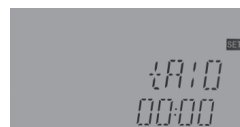
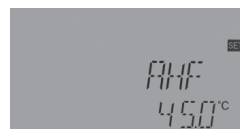

- ▶ Press “↑” button, “tA1F 00:00” displays on the screen
- ▶ Press “SET” button, hour “00” blinks on the screen
- ▶ Press “↑”, “↓” button, to adjust hour of the close time of the first time - section of thermostat function
- ▶ Press “SET” button, minute “00” blinks on the screen
- ▶ Press “↑”, “↓” button, to adjust minute of the close time of the first time - section of thermostat function
- ▶ Press “SET” or “ESC” button, to confirm the setting
- ▶ Press “↑” button, access the second time-section set, do same like above steps, to set the time for the second and third time-section

If it is needed to deactivate a time-section, just set the start time and close time with same time (for example: 10:00 starts and 10:00 closes also)

6.17.BEEP Beeper fault warning

Function description:

When system has fault (temperature sensor fault, no flow), beeper will send warning. During warning to close beeper sound by ▶ Press “ESC”.

Menu structure						
<pre> graph TD BEEP["BEEP (Main menu) 17"] --> OFFON["OFF/ON"] BEEP --- Submenu </pre>						
Main menu	Submenu 1	Submenu 2	Default set	Adjust range	Adjust step	Description
BEEP			OFF	ON/OFF		Beeper warning function (sensor error, no flow)

BEEP Beeper warning function set

- ▶ Press “SET” key to select sub-menu “BEEP”, “BEEP” displays on the screen

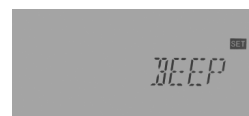

- ▶ Press “SET” button, “BEEP OFF” blinks on the screen
- ▶ Press “SET” button, “OFF” blinks on the screen
- ▶ Press “↑”, “↓” button, to activate this function “BEEP ON” displays on the screen
- ▶ Press “SET” or “ESC” button, to confirm the setting

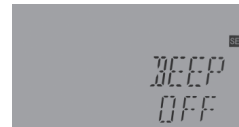

6.18.MAN Manual mode

Function description:

For commissioning and service work, the operating mode of the relays (outputs R1, R2, R3, R4, HR) can be manually adjusted, manual output “On/OFF”



Note: if manual mode is activated, icon blinks on the screen, controller runs for 15 minutes and then switch-off all outputs, control exits manual mode automatically

Menu structure				
Main menu	Submenu	Default set	Adjust range	Description
MAN				Manual mode
	R1	OFF	ON/OFF	R1 On and OFF
	R2	OFF	ON/OFF	R2On and OFF
	R3	OFF	ON/OFF	R3On and OFF
	R4	OFF	ON/OFF	R4On and OFF
	HR	OFF	ON/OFF	HROn and OFF

Function set:

- ▶ Press “SET” key to select menu “MAN”,
- ▶ Press “SET” button, “R1 OFF” displays on the screen
- ▶ Press “SET” button, “OFF” blinks on the screen
- ▶ Press “↑”, “↓” button, to activate this function, “R1 ON” displays on the screen
- ▶ Press “SET” or “ESC” button, to confirm the setting
- ▶ Press “↑” button, “R2” displays, doing like above steps, to activate manual mode of relay R2, R3, R4, HR



6.19. BLPR Block protection function

Function description:

for protect the pumps against blocking after standstill, the controller is equipped with a blocking protection function. This function switches on the relays one after another every day at 12:00 a.m. and runs every relay for 10s at 100 % speed.

Menu structure				
<div style="text-align: center;"> <p><u>BLPR</u> (Main menu) ①⑨</p> <p>↓</p> <div style="display: flex; justify-content: center; align-items: center;"> <div style="border: 1px solid black; padding: 2px 5px; margin-right: 10px;">OFF/ON</div> <div style="border-left: 1px solid black; border-right: 1px solid black; height: 20px; margin-right: 5px;"></div> <div>Submenu</div> </div> </div>				
Main menu	Submenu	Default set	Adjust range	Description
BLPR				Block protection function
		OFF	ON/OFF	On and off this function

Functionset:

- ▶ Press “SET” key to select menu “BLPR”,
- ▶ Press “SET” button, “BLPR OFF” displays on the screen
- ▶ Press “SET” button, “OFF” blinks on the screen
- ▶ Press “↑”, “↓” button, to activate this function “BLPR ON” displays on the screen

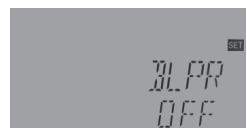
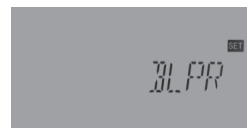

► Press “SET” or “ESC” button, to confirm the setting

6.20.OTDI Thermal disinfection function

Function description:

Thermal disinfection

Thermal disinfection function helps to prevent the spread of Legionella in DHW tanks by systematically activating the backup-heating. One sensor and one relay can be selected for this function.

For thermal disinfection, the temperature at the allocated sensor should be monitored. During the monitoring period PDIS, this protection function ensures the temperature of tank exceeds continuously the preset disinfection temperature TDIS for the entire disinfection period DDIS., Thermal disinfection can only be completed when the disinfection temperature is exceeded for the duration of the disinfection period without any interruption.

The monitoring period PDIS starts as soon as the temperature at the allocated sensor falls below the disinfection temperature TDIS, once the monitoring period PDIS ends, disinfection period SDIS starts, the allocated reference relay activates the backup heating, and SDIS disinfection time counts down,if the temperature at the allocated sensor exceeds the disinfection temperature, thermal disinfection heating period DDIS starts, count down time displays, count down time ends, thermal disinfection function stops.

Main menu	Submenu	Default set	Adjust range	Adjust step	Description
OTDI		OFF	ON/OFF		Disinfection function
	PDIS	7d	0-30d	1d	Disinfection monitoring

					time - section
	DDIS	10min	1-180	1min	Disinfection heating runtime
	TDIS	70°C	0-90°C	1°C	Disinfection temperature set
	SDIS	18:00	00:00-21:00	1:00	Start time of disinfection

Function set:

- ▶ Press “SET” key to select menu “OTDI”,
- ▶ Press “SET” button, “OTDI OFF” displays on the screen
- ▶ Press “SET” button, “OFF” blinks on the screen
- ▶ Press “↑”, “↓” button, to activate this function “OTDI ON” displays on the screen
- ▶ Press “SET” or “ESC” button, to confirm the setting
- ▶ Press “↑” button, “PDIS 07” displays on the screen
- ▶ Press “SET” button, “07” blinks on the screen
- ▶ Press “↑”, “↓” button, to adjust monitor period of disinfection function (unit: day),
- ▶ Press “SET” or “ESC” button, to confirm the setting
- ▶ Press “↑” button, “DDIS 10Min” displays on the screen
- ▶ Press “SET” button, “10” blinks on the screen
- ▶ Press “↑”, “↓” button, to adjust disinfection heating time
- ▶ Press “SET” or “ESC” button, to confirm the setting
- ▶ Press “↑” button, “TDIS 70°C” displays on the screen
- ▶ Press “SET” button, “70°C” blinks on the screen
- ▶ Press “↑”, “↓” button, to adjust disinfection heating temperature
- ▶ Press “SET” or “ESC” button, to confirm the setting
- ▶ Press “↑” button, “SDIS18:00” displays on the screen
- ▶ Press “SET” button, hour “18” blinks on the screen
- ▶ Press “↑”, “↓” button, to adjust the start time of disinfection function

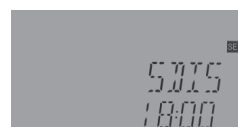
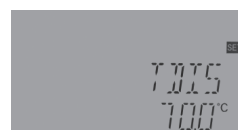
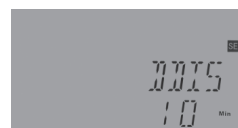

► Press “SET” or “ESC” button, to confirm the setting

6.21.OPARR Parallel relay

Function description:

Due to system different, for example, the R4 output port is used for the selected auxiliary function (refer system diagram auxiliary function 4.2), then only one function can be activated , and other functions are automatically off, “NONE” displays on the screen. If this function should be triggered, then disable current function.

According the different selected system, the relay assigned to the function may be different. With this function, e. g. a valve can be controlled in parallel to the pump via a separate relay.

If solar loading takes place (R1 and / or R2) or if a solar function is active, then the selected parallel relay will be energized too. The parallel relay can also energize the parallel pump inversely.

INVE OFF(valve mode), means R1/R2 triggered, parallel reply is also triggered.

INVE ON (pump mode), means R1/R2 triggered, parallel reply is switched-off



If icon displays on the screen, it indicates valve mode function is enabled,  blinks on the screen, and valve is switched on.



If icon displays on the screen, it indicates pump mode function is enabled,  blinks on the screen, and pump is running.



Note: If R1and/ or R2isin manual mode, then its parallel relay won't be energized.

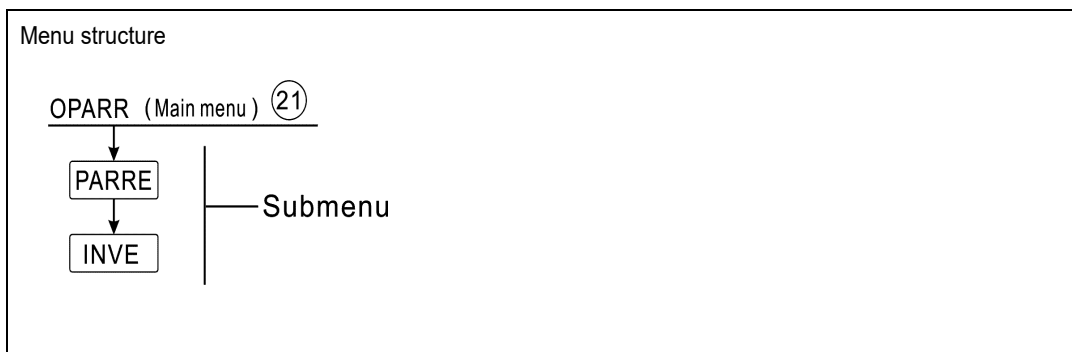

Main menu	Submenu	Default set	Adjust range	Adjust step	Description
OPARR		OFF	ON/OFF		Parallel relay on/ off
	INVE	OFF	ON/OFF		Parallel relay logic on/off

Function set:

- ▶ Press “SET” key to select menu “OPARR”,
- ▶ Press “SET” button, “OPARR OFF” displays on the screen
- ▶ Press “SET” button, “OFF” blinks on the screen
- ▶ Press “↑”, “↓” button, to activate this function “OPARR ON” displays on the screen
- ▶ Press “SET” or “ESC” button, to confirm the setting
- ▶ Press “↑” button, “INVE OFF” displays on the screen
- ▶ Press “SET” button, “OFF” blinks on the screen
- ▶ Press “↑”, “↓” button, to activate this function, “INVE ON” displays on the screen
- ▶ Press “SET” or “ESC” button, to confirm the setting

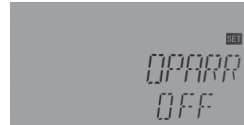

6.22.OHQM Heat quantity measurement

Function description:

The heat quantity measurement can be carried out in 3 different ways:

- 1) Fixed flow rate (with normal glass flow meter)
- 2) With Grundfos flow sensor VFS.
- 3) With rotary blade flow meter FRT

According to the temperature from sensor on the flow pipe(T6) , on the return pipe(T5) and the entered flow rate at 100% pump speed, controller can calculate the heat quantity.

 Note: picture of above mention flow meter see accessory paragraph 10

- Heat quantity measurement with fixed flow rate value

Under menu FTYP to set the flow rate type 1

Read the flow rate (l/min) and enter this value into the controller under the FMAX menu

Adjust the antifreeze type and concentration of the heat transfer fluid under menu MEDT and MED%.

- Antifreeze liquid type:

0: Water

1: Propylene glycol

2: Ethylene glycol

3: Tyfocol LS / G-LS

- Heat quantity measurement with Grundfos Direct Sensor VFS:

If Grundfos sensor VFS is selected for calculating heat quantity, firstly you should activate VFS function under menu FS/GFDS, and select measurement range, default value is 1-12L/min.

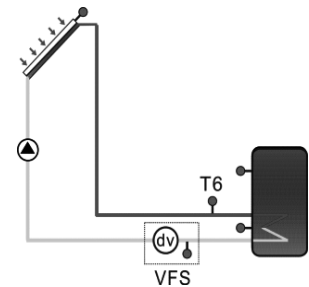

The heat quantity measurement uses the temperature difference between flow sensor T6 and return sensor TVFS and the flow rate transmitted by the VFS sensor. (VFS is Grundfos Direct flow rate meter, TVFS: temperature from Grundfos Direct meter VFS)

i Note:

- 1) Sensor of flow and return pipe for heat quantity measurement is default set in every system, it cannot be set.
- 2) Flow checking function is only available when a VFS type Grundfos Direct Sensor is connected to the system.

- Adjust the antifreeze type and concentration of the heat transfer fluid under menu MEDT and MED%.

T6: temperature sensor of flow pipe

TVFS: temperature sensor of return pipe

If VFS sensor is not corrected to be connected to the controller, icons  will blinks on the screen, temperature zone displays L/M - - - .

- Heat quantity measurement with Rotary blade flow Meter FRT

Under menu FTYP to set flow rate type 3 (FRT)

The heat quantity measurement uses the temperature difference

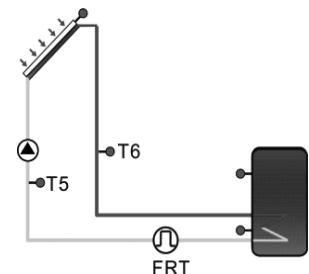

between flow sensor T6 and return sensor T5 and flow rate transmitted by the flow meter FRT
 Select the antifreeze type and concentration of the heat transfer fluid under menu MEDT and MED%.

i Note: If Rotary blade flow Meter FRT is selected for calculating heat quantity, firstly you should activate FRT function under menu FS/FRT

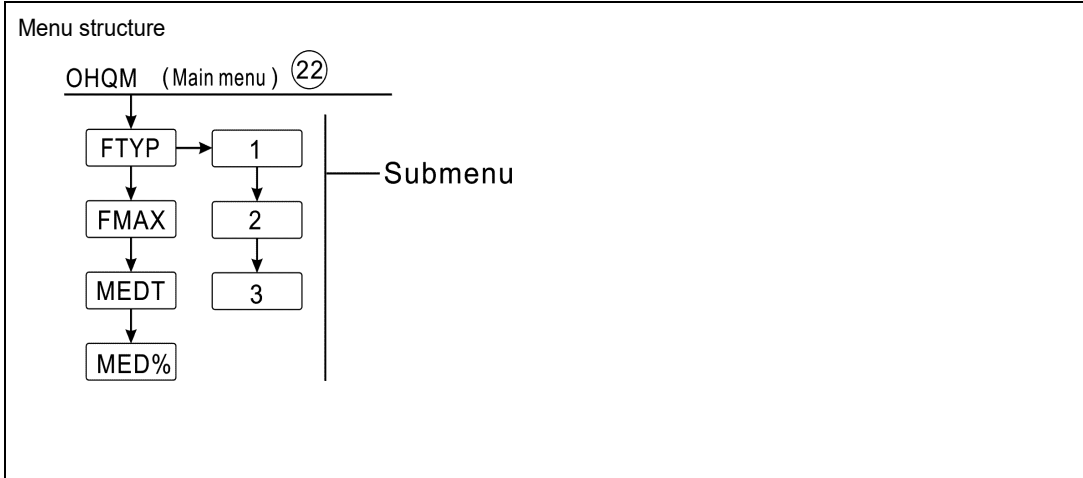

Main menu	Submenu	Submenu	Default set	Adjust range	Adjust step	Description
OHQM	1	2	OFF	ON/OFF		Thermal energy measurement
	FTYP		1	1, 2, 3		Flow sensor selection 1: Fix flow value (glass tube flow meter) 2: Groundfos flow sensor VFS 3: Rotary blade flow meter FRT
	FMAX		6L/min	0.5-100L/min	0.1	Entering the flow rate (for glass tube flow meter)
	MEDT		3	0-3		Heat transfer Liquid 0: Water 1: Propylene glycol 2: Ethylene glycol

						3: Tyfocol LS / G-LS
	MED%		45%	20-70%	1%	Concentration of the heat transfer fluid

Function set:

- ▶ Press “SET” key to select menu “OHQM”,
- ▶ Press “SET” button, “OHQM OFF” displays on the screen
- ▶ Press “SET” button, “OFF” blinks on the screen
- ▶ Press “↑”, “↓” button, to activate this function “OHQM ON” displays on the screen
- ▶ Press “SET” or “ESC” button, to confirm the setting
- ▶ Press “↑” button, “FTYP 1” displays on the screen
- ▶ Press “SET” button, “1” blinks on the screen

- ▶ Press “↑”, “↓” button, to select type of flow meter (1,2,3)
- ▶ Press “SET” or “ESC” button, to confirm the setting
- ▶ Press “↑” button, “FMAX 6” displays on the screen
- ▶ Press “SET” button, “6” blinks on the screen
- ▶ Press “↑”, “↓” button, to adjust the flow rate value
- ▶ Press “SET” or “ESC” button, to confirm the setting
- ▶ Press “↑” button, “MEDT 3” displays on the screen
- ▶ Press “SET” button, “3” blinks on the screen
- ▶ Press “↑”, “↓” button, to select the type of heat transfer liquid
- ▶ Press “SET” or “ESC” button, to confirm the setting
- ▶ Press “↑” button, “MED% 45” displays on the screen
- ▶ Press “SET” button, “45” blinks on the screen
- ▶ Press “↑”, “↓” button, to adjust the concentration of the heat transfer fluid
- ▶ Press “SET” or “ESC” button, to confirm the setting

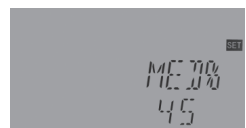
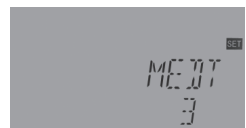

6.23.FS Flow meter selection and flow rate monitor

Function Description:

Under this menu, the Grundfos direct sensor (VFS) and rotary blade flow meter (FRT) can be activated or deactivated, and its flow rate measurement range can be set also.

FLOW: Flow rate monitor function

Flow rate monitor (FLOW) is designed to detect the malfunction which leads to a standstill of liquid flow, and as a reaction to shut down the corresponding tank. This will prevent system from damage, e. g. through a dry run of the pump.

If the allocated relay (R1) is energized, the flow rate will be monitored at the allocated sensor. After a delay detection time (DELY), an error message will appear when no flow rate is detected at the allocated sensor, icon  blinks on the screen and temperature zone displays L/M0.0.

If the shutdown option has been activated for the flow rate monitoring function, the tank being loaded will be stopped for any further loading until the error message has been acknowledged. When the error message has been handled, the monitoring function will be reactivated.



Note: If the using Grundfos flow rate sensor VFS is removed, then icon  will blink on the screen, and temperature zone displays L/M__.

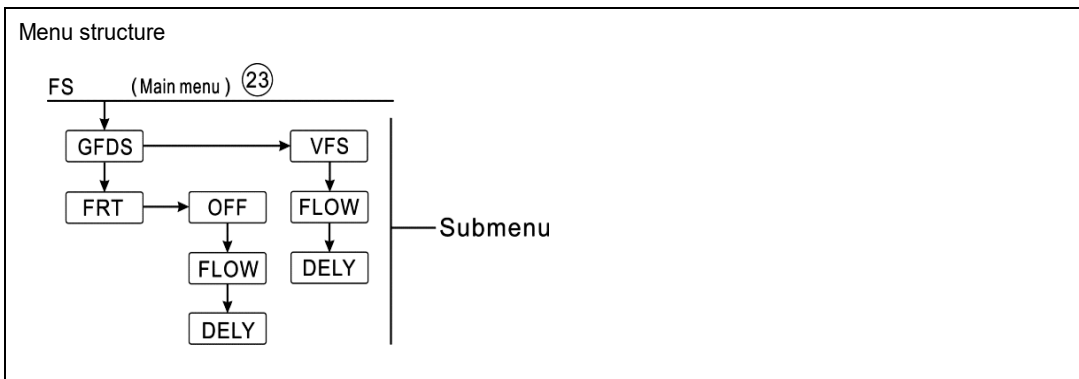

Main menu	Submenu1	Submenu2	Default set	Adjust range	Adjust step	Description	Main menu
FS							Register of flow sensor
	GFDS						Grundfos flow sensor
		VFS	OFF	OFF			Grundfos flow sensor on/off
			1-12				Measurement range of Grundfos

							flow meter(1-12 L/min)
			2-40				Measurement range of Groundfos flow Meter(2-40 L/min)
		FLOW		OFF	ON/OFF		Warning when no flow
		DELY		30s	1-600s	1s	Delay detect time when no flow
	FRT	OFF		OFF	OFF/ ON		Rotary blade flow meter
		FLOW		OFF	ON/OFF		Warning when no flow
		DELY		30s	1-600s	1s	Delay detect time when no flow

Function set:

▶ Press "SET" key to select menu "FS"



▶ Press "SET" button, "GFDS" displays on the screen



▶ Press "SET" button, "VFS OFF" displays on the screen



▶ Press "SET" button, "OFF" blinks on the screen

▶ Press "↑", "↓" button, to activate this function "VFS 1-12V" displays on the screen



▶ Press "↑", "↓" button, to adjust the measurement range of flow meter

▶ Press "SET" or "ESC" button, to confirm the setting

▶ Press "↑" button, "FLOW OFF" displays on the screen



▶ Press "SET" button, "OFF" blinks on the screen

▶ Press "↑", "↓" button, to activate this function, "FLOW ON" displays on the screen

▶ Press "SET" or "ESC" button, to confirm the setting

▶ Press "↑" button, "DELY30" displays on the screen

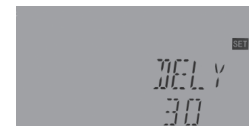

▶ Press "SET" button, "30" blinks on the screen

▶ Press "↑", "↓" button, to adjust the delay detect time when no flow

▶ Press "SET" or "ESC" button, to confirm the setting

▶ Press "ESC" key to return to previous menu

▶ Press "↑" button, "FRT" displays on the screen



- ▶ Press “SET” button, “FRT OFF” displays on the screen
- ▶ Press “SET” button, “OFF” blinks on the screen
- ▶ Press “↑”, “↓” button, to activate this function, “FRT ON” displays on the screen
- ▶ Press “SET” or “ESC” button, to confirm the setting
- ▶ Press “↑” button, “FRT” displays on the screen
- ▶ Press “SET” button, “FLOW OFF” displays on the screen, same process as above step.



6.24.UNIT Unit switch

Under this menu, below unit can be set:

TEMP: temperature

ENEG: heat quantity, 1 for KWH, 2 for BTU

The units can be switched during operation.

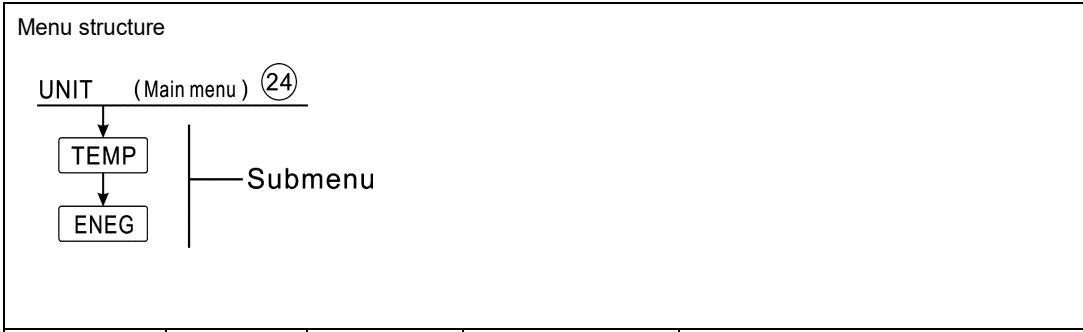

Main menu	Submenu	Default set	Adjust range	Description
UNIT				Unit Switch
	TEMP	°C	°C/°F	°C-°F Switch
	ENEG	1(Wh)	1(Wh) /2(BTU)	Energy unit switch

Function set:

- ▶ Press “SET” key to select menu “UNIT”
- ▶ Press “SET” button, “TEMP °C” displays on the screen
- ▶ Press “SET” button, “°C” blinks on the screen
- ▶ Press “↑”, “↓” button, to select temperature unit
- ▶ Press “SET” or “ESC” button, to confirm the setting



- ▶ Press “↑” button, “ENEG 1” displays on the screen
- ▶ Press “SET” button, “1” blinks on the screen
- ▶ Press “↑”, “↓” button, to select thermal energy unit
- ▶ Press “SET” or “ESC” button, to confirm the setting



6.25.WLAN WiFi module configuration

Function description:

Each controller’s WiFi connection is configured to wait for connection at factory. You need to add a controller and set up the network (see WiFi configuration instructions). If the controller already has network information, you need to reconfigure it to another network, you can reset the original WiFi parameters in the menu, the specific steps are as follows:

Enter WLAN menu

Menu path: WLAN->ONOF->RES. Press ”Set” key, “YES” flashes on the screen, Long Press the ”Set” key to clear the previous WiFi configuration information and enter the current WiFi setting state (the WiFi indicator blinks and the WiFi icon on the display blinks).



Note: Shortcut key reset WiFi configuration information: Hold down “↑” for three seconds, the controller automatically reset the WiFi module configuration information (WiFi indicator blinking, WiFi icon blinking on the display).

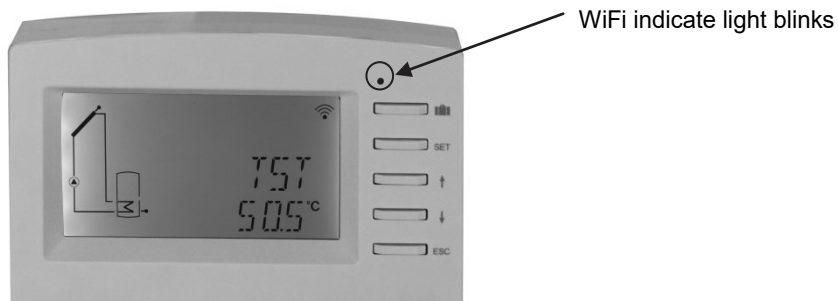

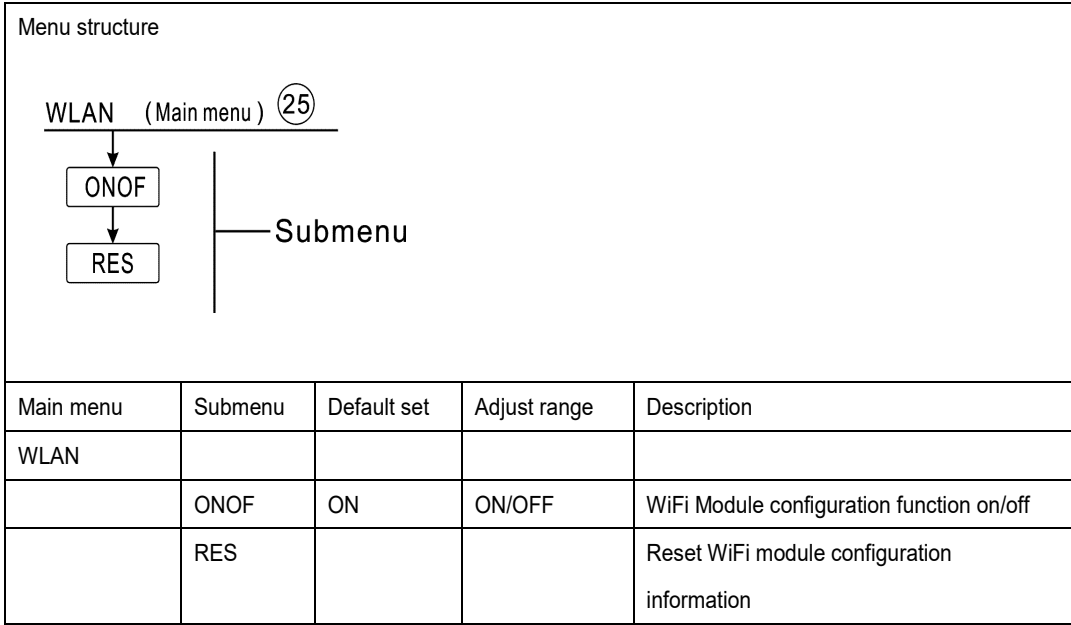

Function set:

- ▶ Press “SET” key to select menu “WLAN”
- ▶ Press “SET” button, “ONOF ON” displays on the screen
- ▶ Press “SET” button, “ON” blinks on the screen
- ▶ Press “↑”, “↓” button, to deactivated this function, ONOF OFF displays
- ▶ Press “SET” or “ESC” button, to confirm the setting
- ▶ Press “↑” button, “RES” displays on the screen
- ▶ Press “SET” button, “YES” blinks on the screen
- ▶ Press “SET” key for 3s, beeper sounds “Di Di Di”, “YES” lighting, indicate WIFI module is recover to factory set.



6.26.RST Reset

Function description:

RSTP (menu parameters): by reset function, all settings can be recovered to the factory default value.

CHQM (accumulated energy): Accumulated heat can be reset to 0

CPT (accumulated pump running time):Accumulated pump running time(R1time / R2time/ R3time)can be reset to 0.

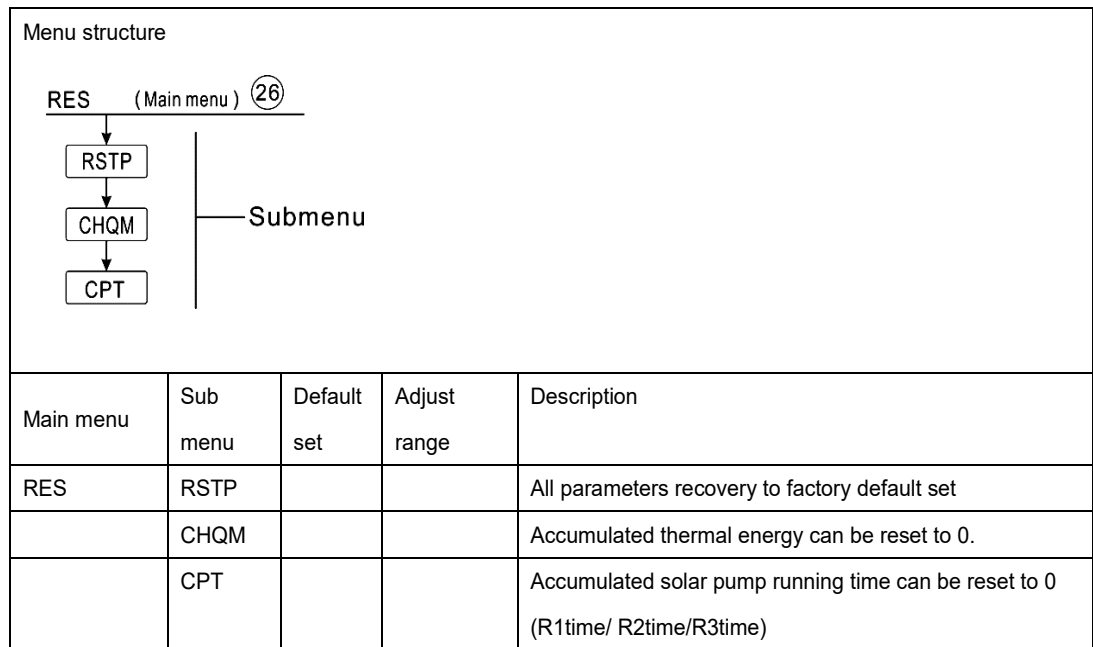

Function set:

- ▶ Press “SET” key to select menu “RES”
 - ▶ Press “SET” button, “RSTP” displays on the screen
 - ▶ Press “SET” button, “YES” blinks on the screen
 - ▶ Press “SET” key for 3 seconds, beeper sounds “di, di, di” remind, and “YES” remains lighting, it indicates system is recovered to the factory set.
 - ▶ Press “ESC” key return to the sub-menu
 - ▶ Press “↑” button, “CHQM” displays on the screen,
 - ▶ Press “SET” button, “YES” blinks on the screen
 - ▶ Press “SET” key for 3 seconds, beeper sounds “di, di, di” remind, and “YES” remains lighting, it indicates system is recovered to the factory set.
- same steps like above, to reset CPT (pump running time)parameters.

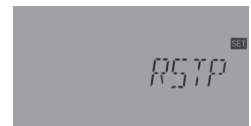

6.27.PASS Password set

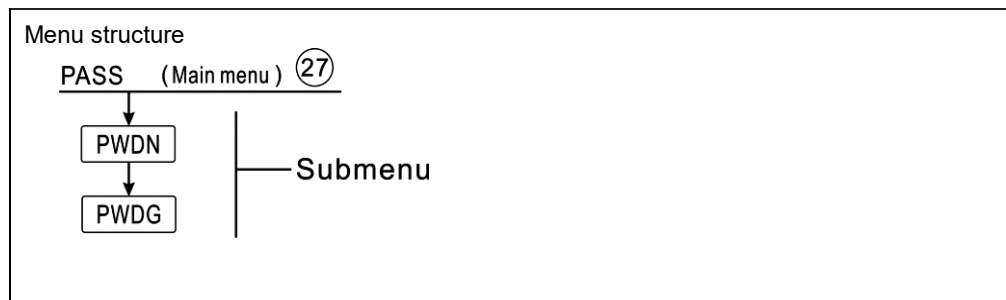

Function set:

- ▶ Press “SET” key to select menu “PASS”
- ▶ Press “SET” button, “PVDN 0000” displays on the screen
- ▶ Press “SET” button, the left digital blinks, ask for a new password
- ▶ Press “↑”, “↓” button, to enter the first digital
- ▶ Press “SET” button, the second digital blinks
- ▶ Press “↑”, “↓” button, to enter the second digital
- ▶ Press “SET” button, the third digital blinks
- ▶ Press “↑”, “↓” button, to enter the third digital
- ▶ Press “SET” button, the forth digital blinks
- ▶ Press “↑”, “↓” button, to enter the forth digital
- ▶ Press “SET” button, “PVDG 0000” displays, Press “SET” to enter password again.

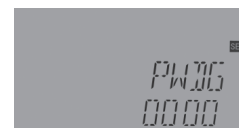
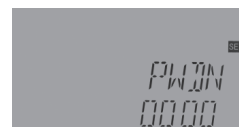

Doing like above steps to enter new password and confirm, then “OK” displays on the screen. It indicates new password is set successfully.

i Note: If the password is forgot, it is impossible to recover, but you can recover the password to factory set, then you can reenter a password like above steps description , doing like following to recover to factory set.

- ▶ Press Switch-off the power to controller
- ▶ Press Hold down “ESC” key
- ▶ PressReconnect the power supply, beeper sounds “di, di, di” remind, and then release “ESC” button, password is recovered to the factory set, (factory set password is 0000),

7.Holiday function

Function description:



The holiday function is designed to run the system when no water consumption is expected, e.g. during a holiday absence. This function will cool down the system to reduce the thermal load.

2 cooling functions are available: tank cooling (OSTC) and tank heat transfer (OHDP).



Note: Controller is designed to run tank heat transfer (OHDP) function priority, when tank heat transfer (OHDP) function is deactivated, then tank cooling function (OSTC) runs automatically in turn.

Activated / deactivate holiday function

- ▶ Press “” key for 3 seconds, “HDAY 05” displays.
- ▶ Press “↑”, “↓” key to adjust days of holiday, adjustable range 0-99 days.
- ▶ Press “SET” or “ESC” button, to confirm the setting
- ▶ Press “” key again to deactivate holiday function



Note: this function is only activated when you are not at home for a longer time, when you return from holiday, please deactivate this function in time.

8. Protection function

8.1. Screen protection

When no any Press on key for 5 minutes, screen protection is activated automatically, and then LED background lamp is switched-off. Press any key to light LED lamp again.

8.2. Trouble protection

When there is a break or short circuit between the connection of temperature sensors, flow meter, controller switches off the corresponding functions and no more output signals are given, at the same time error signal  appears on the screen and indication lamp flashes.

- ▶ Press “↑”“↓” key to view the error message.

Note: if any optional sensor has fault or setup error, the indication code and errors of sensors displays alternately.

Code Description:

No.	Display code	Description
1	THS	Target tank sensor THS for timing heating function
2	SMAXS	Sensor for tank maximum temperature limitation SMAX
3	AHS	Sensor for thermostat function AHS
4	TANK	Tank sensor for heating circuit return pipe heated function TANK

8.3.Trouble checking

The built-in controller is a qualified product, which is conceived for years of continuous trouble-free operation. If a problem occurs, the most of causes is from the peripheral components but no relation with controller itself. The following description of some well-known problems should help the installer and operator to isolate the problem, so that the system can be put into operation as quickly as possible and to avoid unnecessary cost. Of course, not all possible problems can be listed here. however, most of the normal problems encountered with the controller can be found in the list below, only return the controller to seller when you are sure that none of the problems listed below is responsible for the fault.

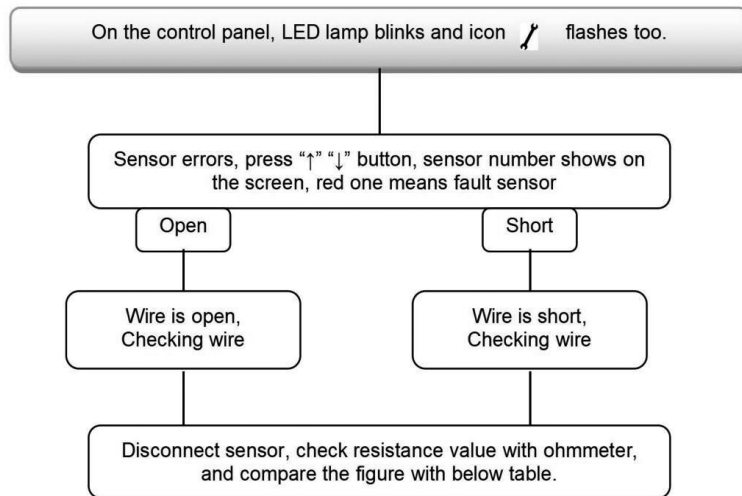

PT1000 resistance value

℃	0	10	20	30	40	50	60	70	80	90	100	110	120
Ω	1000	1039	1077	1116	1155	1194	1232	1270	1309	1347	1385	1422	1460

NTC 10K B=3950 resistance value

℃	0	10	20	30	40	50	60	70	80	90	100	110	120
Ω	33620	20174	12535	8037	5301	3588	2486	1759	1270	933	697	529	407

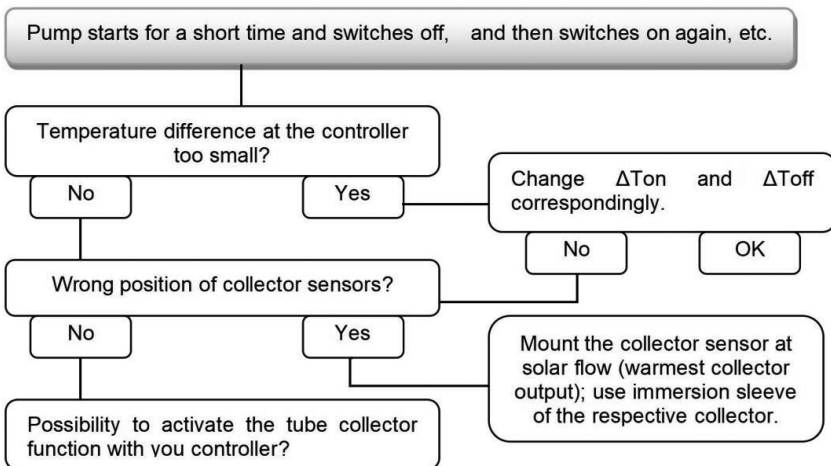
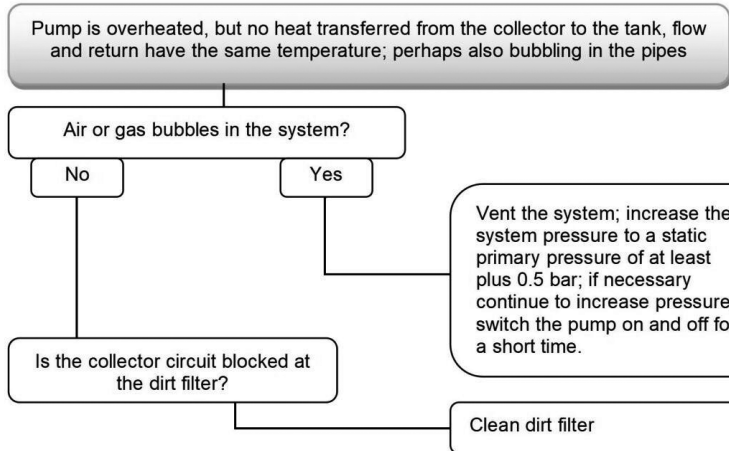
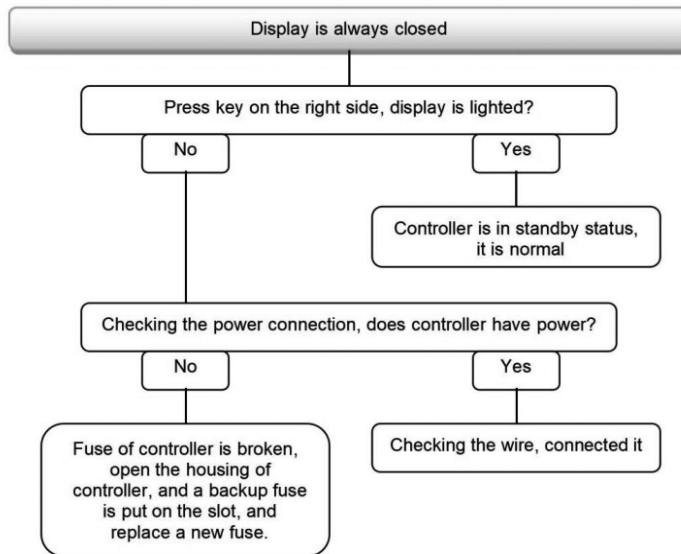

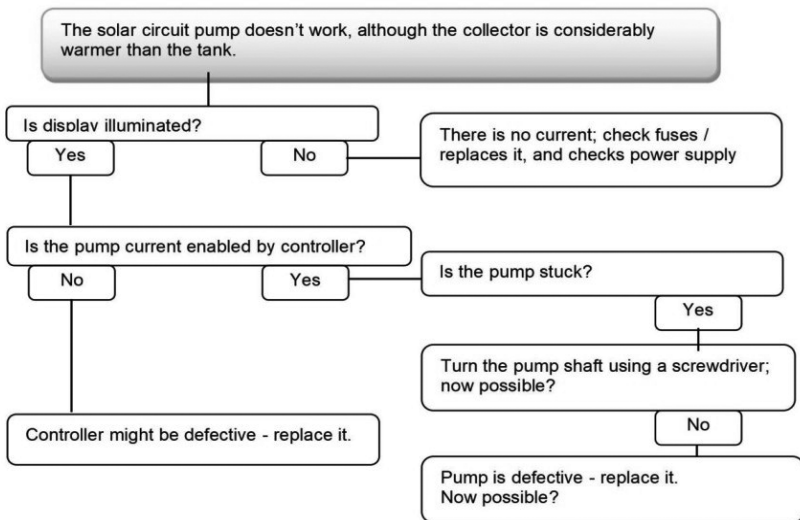
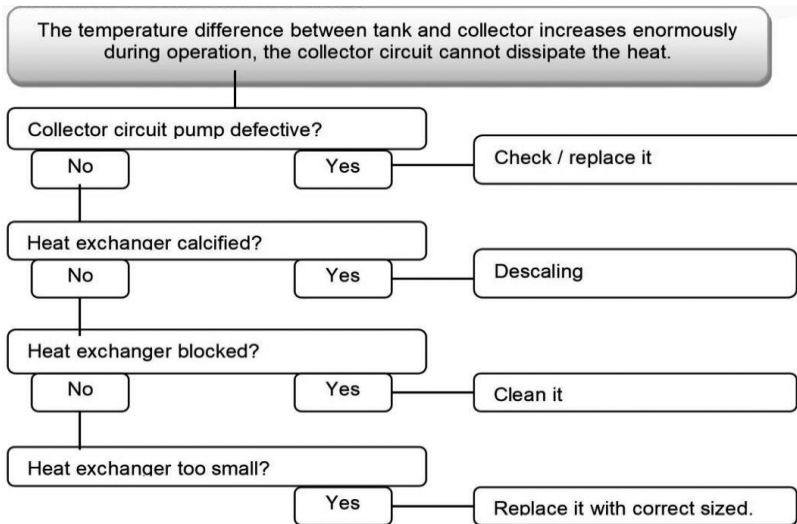
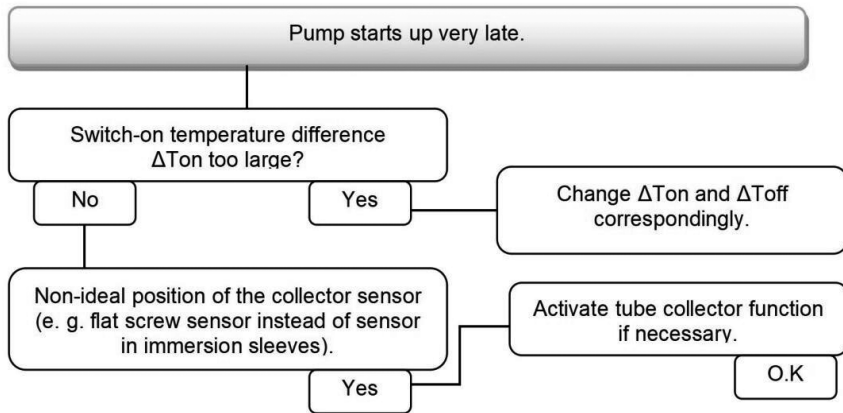

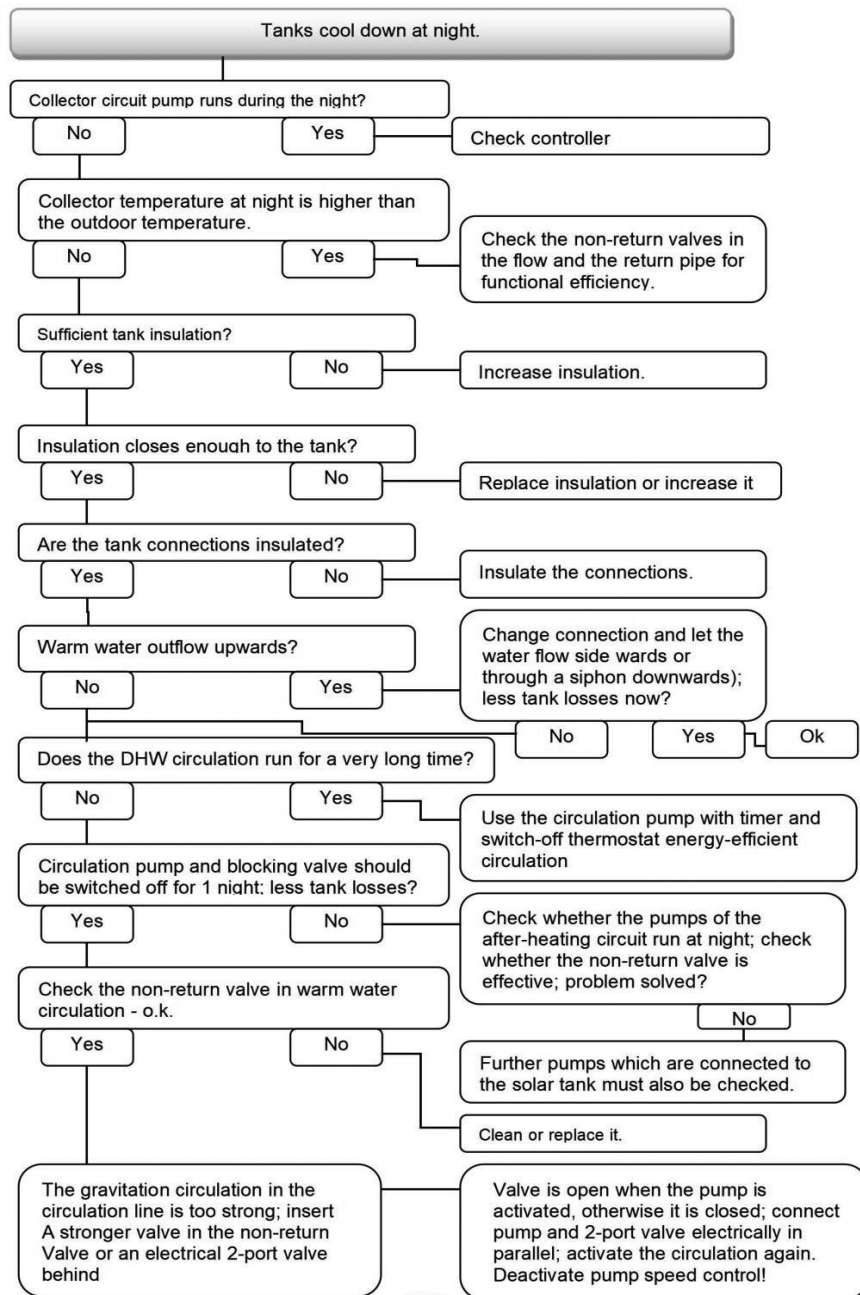





9. Quality Guarantee

Manufacturer provides following quality responsibilities to end-users: within the period of quality responsibilities, manufacturer will exclude the failure caused by production and material selection. A correct installation will not lead to failure. When the user takes incorrect processing methods, incorrect installation, improper or rough handling, wrong connection of system and incorrect operation, the

quality assurance liability is invalid.

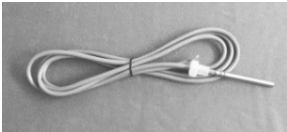
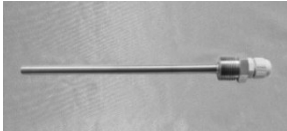
The quality warranty expires within 24 months after the date of purchasing the controller.

10. Accessories

<p>A01: High accurate Pt1000 sensor for Collector Parameter: PT1000, $\Phi 6 \times 50$mm, with 1.5m cable</p>	
<p>A02: High accurate sensor for tank and pipe Parameter: NTC10K, B=3950, $\Phi 6 \times 50$mm, with 3m cable</p>	
<p>A05: 304 stainless steel thermowell 304 stainless steel, with thread 1/2' OT, Size: $\Phi 8 \times 200$mm</p>	
<p>VFS Groundfos Direct flow meter sensor Parameter: 1-12l/min, 2-40l/min</p>	
<p>FRT electronic flow Meter Connector: M thread 3/4 Power: 5-24V/DC</p>	
<p>SR802: Unit for high power electrical heater Dimension: 100mm*100mm*65mm Power supply: AC180V ~ 264V, 50/60Hz Suitable power: ≤ 4000W Available ambient temperature: $-10 \sim 50^{\circ}\text{C}$ Waterproof grade: IP43</p>	

SR223 WiFi App User Manual

Content

SR223 WiFi App User Manual	1
1. Background	2
2. Install App for SR223.....	2
(1) Find app.....	2
(2) Open app.....	2
3. Add a controller	2
(1) Find controller automatically	2
(2) Find controller manually.....	3
(3) Input WiFi information	3
(4) Wait for controller to connect to network.	4
(5) Added successfully	5
4. How to add controller for distributor	6
5. Controller management.....	9
(1) Reset WiFi configuration	9
(2) WiFi Icon definition	9
(3) LED definition	10

Historic

Revision	Author	Date	Description
1.0	Nick	2024.4.27	Initial version to operate app.
1.1	Nick	2024.5.13	Change to SR223

1. Background

SR223 is a heat controller launched by ShuangRi electronic company. Using app, it can easy to know current status of controller and setup some parameters from your mobile phone.

2. Install App for SR223

(1) Find app

In app store, search “tuya” or “Smart Life” and install it as icon below.

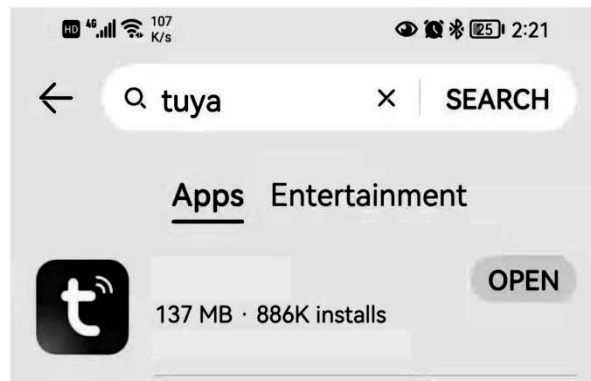

(2) Open app

Check app icon as below, open it.



3. Add a controller

(1) Find controller automatically

Open app, When the LED on SR223 is flashing, the app will pop up a message about network setting, check picture below.



(2) Find controller manually

If there is no pop-up message, you can also add a controller manually, in the auto scan page, it will find out the new controller.

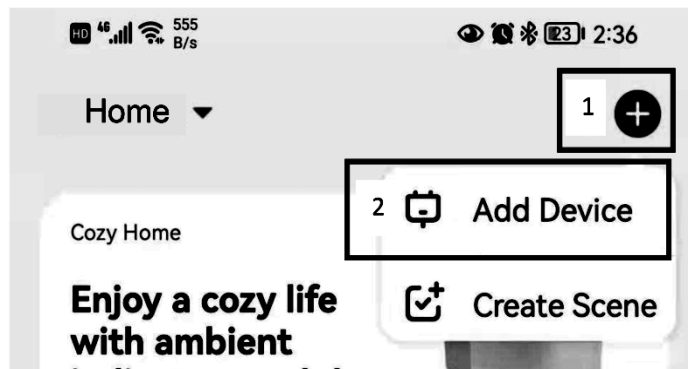

(3) Input WiFi information

WiFi name and WiFi password as picture below

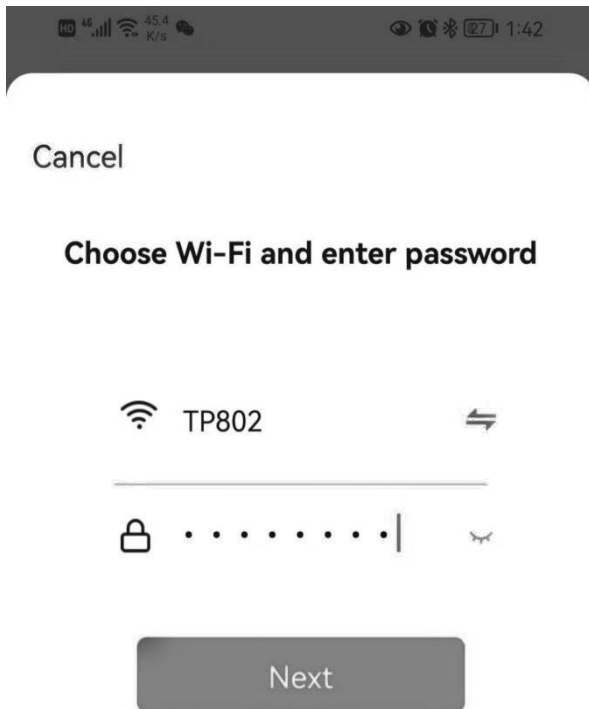

(4) Wait for controller to connect to network.

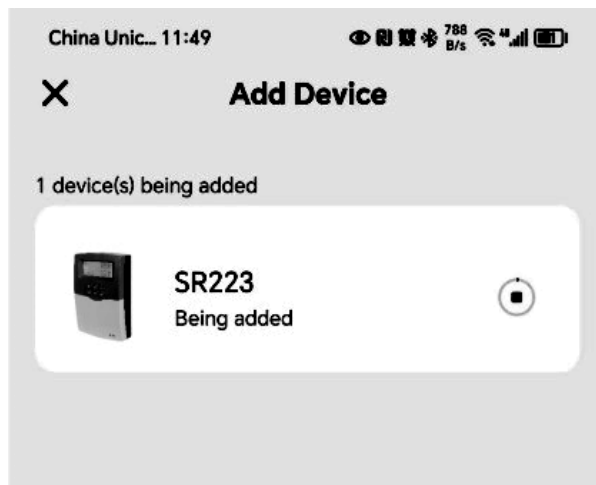

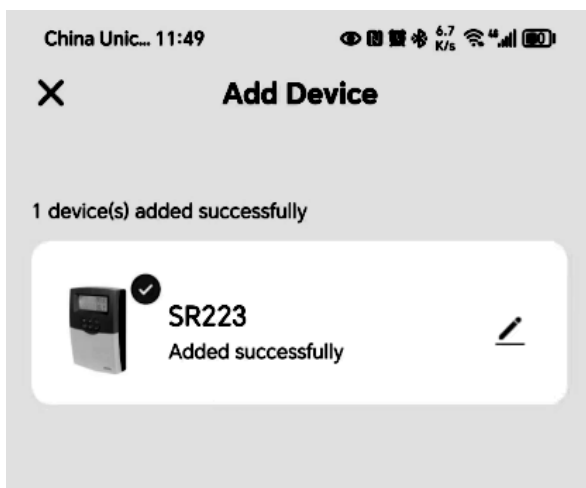

(5) Added successfully

After all, you can see the controller in your app. Check picture below.

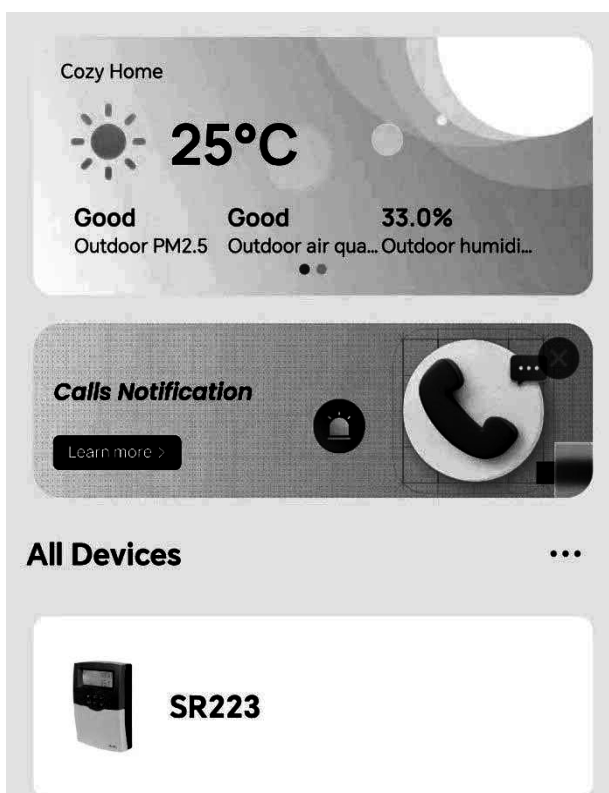



SR223



System Controller For Solar System

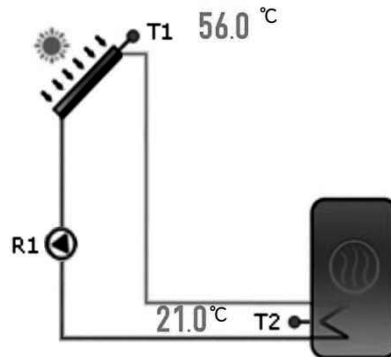

4. How to share controller

There are two methods to allow other to access the controller. First is share it. Second is as a family member.

(1) Share the controller

App can share the controller to others. After shared, other people can access the controller and control it. You can share using "Tu Ya" account directly or other SMS app. Check steps below.

Open the controller ==>Share Device



SR223



- Device Information
- Tap-to-Run and Au...
- Create Group
- Check Device Netw...
- Share Device**
- Message notificatio...

General Settings

FAQ & Feedback >

Add to Home Screen >

Device Update No updates available >

Remove Device



Add Sharing



Share with Account

Share with the Account Add >

Share with Others person(s)



WeChat



Messages



Copy



More

(2) Add a member in the same home

Me ==> Home Management ==> Add Member

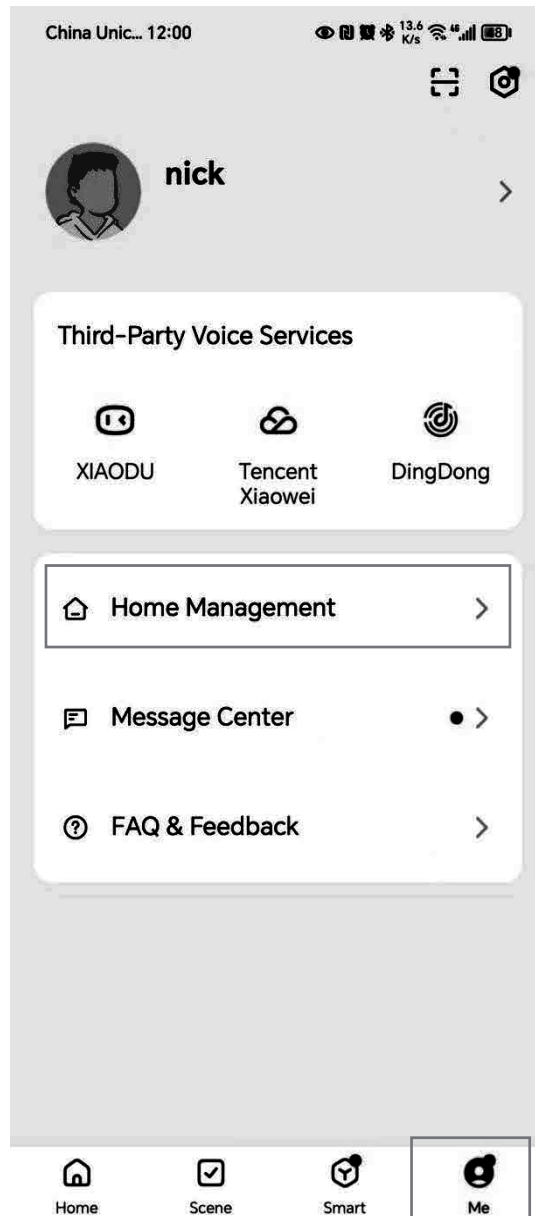

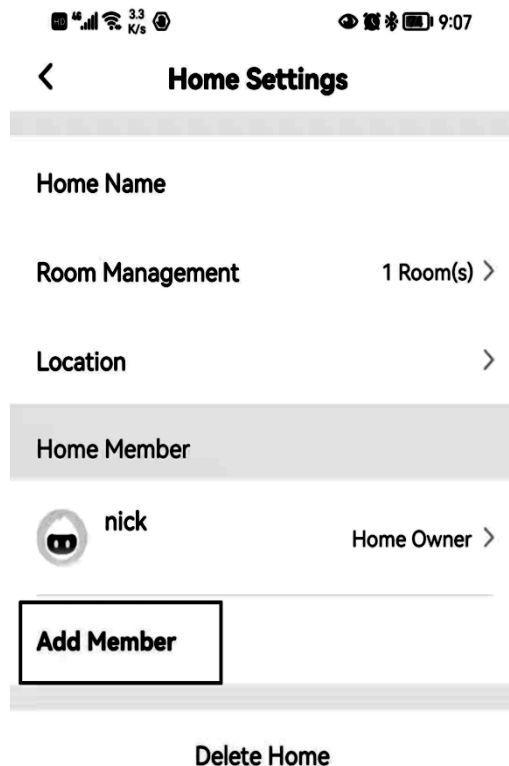

5. Controller management.

(1) Reset WiFi configuration





Each controller after production, it will be in configuration mode. You can using instruction in section 2 to add a controller to your app. But if the controller already connected to a WiFi router or AP, you want to change to another one, using menu to reset configuration. Steps as below:

- ① Enter to WLAN, setup->WLAN->RES. Press “set” key, the screen will flash with text “YES”, Long press “set” key. The old configuration will be cleared.
- ② Using app to add a controller as section 2.

(2) WiFi Icon definition

Check table below for detailed meaning of WiFi icon.



No	Display	Meaning	Action
1		Connected OK	No Action
2		1. WiFi module broken 2. No WiFi module 3. WiFi module is initializing	Wait for 1 minute, if it is still not changed, then check WiFi module
3	 Flash	1. WiFi module is connecting to network. 2. WiFi module is waiting for setting	Setup controller's WiFi setting.
4	 Flash	1. WiFi connected to WiFi AP, but AP can't access ShuangRi server.	Check AP's setting, whether connected to internet.

(3) LED definition

Check table below for detailed meaning of WiFi LED.

No	LED	Meaning	Action
1	ON	Connected OK	No Action
2	OFF	1. WiFi module broken 2. WiFi module disabled 3. Network not Connect	1. Check WiFi configuration whether it is enabled. 2. Check WiFi module whether it is broken.
3	Flash	Waiting for setup	Setup WiFi module

